

ADDENDUM 1

00273



TO THE

OE OPERATIONS WORK PLAN

FOR THE

OE REMOVAL ACTION

OPEN BURNING GROUNDS SENECA ARMY DEPOT ACTIVITY ROMULUS, NEW YORK

Contract Number: DACA87-97-D-0005

Task Order: 0003

Prepared For:



The U.S. Army Engineering and Support Center
Huntsville, Alabama

Prepared By:



2229 Old Highway 95
Lenoir City, Tennessee 37932

June 1999

ADDENDUM 1
TO THE
OE OPERATIONS WORK PLAN
FOR THE
OE REMOVAL ACTION

OPEN BURNING GROUNDS
SENECA ARMY DEPOT ACTIVITY
ROMULUS, NEW YORK

Contract Number: DACA87-97-D-0005
Task Order: 0003

Prepared For:

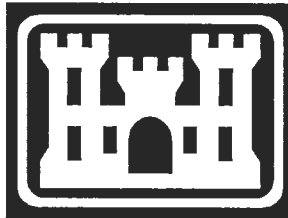

The U.S. Army Engineering and Support Center
Huntsville, Alabama

Prepared By:



2229 Old Highway 95
Lenoir City, Tennessee 37932

June 1999



TABLE OF CONTENTS

Section	Page
CHAPTER 1: GENERAL	1-1
1.0 INTRODUCTION	1-1
1.1 PURPOSE	1-1
1.2 SITE DESCRIPTIONS AND HISTORY	1-1
1.3 WORK PLAN ORGANIZATION	1-1
1.4 CHANGES TO THE WORK PLAN	1-1
CHAPTER 2: UXO OPERATIONAL PLAN	2-1
2.0 INTRODUCTION	2-1
2.1 PROJECT ORGANIZATION	2-1
2.2 EODT PERSONNEL RESPONSIBILITIES	2-1
2.2.1 Program Manager	2-1
2.2.2 Project Manager	2-1
2.2.3 Senior UXO Supervisor	2-3
2.2.4 Occupational Safety and Health Manager	2-3
2.2.5 Site Safety and Health Officer/Quality Control Specialist	2-3
2.2.6 Quality Control Manager	2-3
2.3 APPROACH AND OPERATIONAL SEQUENCE	2-4
2.3.1 General	2-4
2.3.2 Project Operational Sequence	2-4
2.3.3 Project Assumptions	2-5
2.4 PRE-MOBILIZATION	2-5
2.5 MOBILIZATION	2-5
2.6 REMEDIATION	2-6
2.6.1 General Site Organization and Practices	2-6
2.6.2 Compliance with Plans and Procedures	2-7
2.6.3 Safety and Operational Training and Briefings	2-7
2.6.4 Preparation of Work Areas	2-7
2.6.5 Location Surveying and Mapping	2-7
2.6.6 Visual Survey	2-7
2.6.7 Vegetation Removal	2-7
2.6.8 OE Magnetometer Survey	2-8
2.6.9 Geophysical Investigation	2-8
2.6.10 Anomaly Investigation for Subsurface Clearances	2-8



2.6.11 Disposal Operations 2-9
2.6.12 Soil Excavation and Screening 2-12

2.6.13 Quality Control Inspections 2-15
2.7 PROJECT CLOSE-OUT 2-15
2.8 PROJECT SUBMITTALS 2-15

CHAPTER 3: SITE-SPECIFIC SAFETY AND HEALTH PLAN 3-1

CHAPTER 4: GEOPHYSICAL EQUIPMENT PLAN 4-1
4.0 INTRODUCTION 4-1
4.1.1 Search Lanes 4-1
4.1.2 Geophysical Survey 4-1
4.1.3 Equipment 4-2
4.2 DATA REDUCTION 4-2

CHAPTER 5: EQUIPMENT PLAN 5-1
5.0 GENERAL 5-1
5.16 PROJECT REQUIRED EQUIPMENT AND SUPPLIES 5-1

CHAPTER 6: LOCATION SURVEYING AND MAPPING PLAN 6-1
6.0 GENERAL 6-1

CHAPTER 7: ENVIRONMENTAL PROTECTION PLAN 7-1

CHAPTER 8: QUALITY CONTROL PLAN 8-1

CHAPTER 9: WORK DATA COST MANAGEMENT PLAN 9-1
9.0 GENERAL 9-1
9.1 PROJECT ORGANIZATION 9-1
9.2 PROJECT DAILY SCHEDULE 9-1
9.2.1 Performance Data 9-1
9.3 TASK ORDER COST DATA 9-2
9.3.1 Manpower Requirements 9-2
9.4 TASK AND PROJECT COSTS 9-4
9.4.1 Government Furnished Equipment 9-5
9.4.2 Consumable Supplies 9-5



LIST OF ACRONYMS AND ABBREVIATIONS

ABIH	American Board of Industrial Hygienists
AR	Army Regulation
BATF	Bureau of Alcohol, Tobacco and Firearms
BIP	blow-in-place
BRAC	Base Realignment and Closure
CA	Contract Administrator
CEHNC	U.S. Army Engineering and Support Center, Huntsville
CFR	Code of Federal Regulations
CIH	Certified Industrial Hygienist
CSHP	Corporate Safety and Health Program
DID	Data Item Description
DoD	Department of Defense
DOT	Department of Transportation
DRMO	Defense Reutilization and Marketing Office
EMM	earth moving machinery
EODT	EOD Technology, Inc.
EPP	environmental protection plan
ER	Engineering Regulation
EZ	Exclusion Zone
FAR	Federal Acquisition Regulation
GFE	government furnished equipment
IAW	in accordance with
KO	Contracting Officer
LS&M	location surveying and mapping
MDA	Munitions Destruction Area
mm	millimeter
NEW	net explosive weight
OB	open burn
OD	open detonation
OE	ordnance and explosives
ORS	ordnance related scrap
OSHA	Occupational Safety and Health Administration
OSHM	Occupational Safety and Health Manager

LIST OF ACRONYMS AND ABBREVIATIONS (continued)

OSS	CEHNC On-site Safety Specialist
PM	Project Manager
PO	purchase order
PPE	personal protective equipment
PWD	public withdrawal distance
QA	quality assurance
QC	quality control
QCI	quality control inspection
QCM	Quality Control Manager
QCS	Quality Control Specialist
SEDA	Seneca Army Depot Activity
SOP	standard operating procedure
SOW	Statement of Work
SSHO	Site Safety and Health Officer
SSHP	Site Safety and Health Plan
SUXOS	Senior UXO Supervisor
TO	Task Order
USA	U.S. Army
USACE	U.S. Army Corps of Engineers
UXO	unexploded ordnance
UXOSP	UXO Specialist
WDCMP	Work Data and Cost Management Plan
WP	work plan
WZ	Work Zone

(This space intentionally left blank)



CHAPTER 1: GENERAL

1.0 INTRODUCTION

This Work Plan (WP) addendum describes the procedures, sequence, and resources EOD Technology, Inc. (EODT) will utilize for an ordnance and explosives (OE) removal action (RA) at the Open Burning Ground (OBG). This site is located within the Seneca Army Depot Activity (SEDA), near Romulus, New York, with the work conducted at this site being authorized by the U.S. Army Engineering and Support Center, Huntsville (CEHNC) under Contract DACA87-97-D-0005.

1.1 PURPOSE

The purpose of this WP addendum is to outline the management structure, technical approach, safety procedures and environmental protection procedures required to perform OE removal operations at the SEDA OBG. All site activities will be conducted in accordance with (IAW) this site-specific WP Addendum, with any deviation from this plan requiring the prior approval of both the EODT Project Manager (PM) and the CEHNC Contracting Officer (KO).

1.2 SITE DESCRIPTIONS AND HISTORY

(No site-specific changes to this paragraph required. Refer to the SEDA Generic WP.)

1.3 WORK PLAN ORGANIZATION

EODT has been tasked with the conduct of several OE characterization and removal projects within the SEDA facility. To minimize reproduction costs and more efficiently address each site-specific SOW, EODT generated a generic WP designed to address the general, facility-wide requirements that EODT will apply to all sites, to include the generic OE location, investigation and disposal procedures that should be applicable to all sites within the SEDA.

When EODT was tasked with conducting the OE removal at the OBG, a distinct SOW was issued to EODT to address the site-specific removal requirements. Under this site-specific SOW, EODT has produced, and submits for approval, this site-specific WP Addendum that will identify the technical approach and site-specific OE operations to be conducted by EODT to meet the OBG SOW.

1.4 CHANGES TO THE WORK PLAN

This WP addendum and the generic WP were developed using available site information at the time of preparation, and may be subject to change. Should any generic or site-specific WP modifications become necessary, the procedures listed below will be followed to ensure the smooth integration of the changes.



1. The EODT PM, SUXOS, Occupational Safety and Health Manager, Site Safety and Health Officer (SSHO), and/or Quality Control Specialist (QCS), as appropriate, will, in conjunction with the CEHNC, review and assess the required changes.
2. If the WP changes have an adverse impact upon site safety, quality, or operations, the affected operations may have to be halted pending CEHNC approval of the changes. However, prior to formal approval of the changes, interim approval of the changes may be provided to facilitate implementation of the changes and minimize production impact. This interim approval may be provided by the CEHNC KO through the on-site OSS. Any interim approval of WP changes will be documented by the EODT SUXOS in the on-site Operational Log.
3. Prior to the implementation of any changes, effected site personnel will be given a briefing related to the changes to ensure full understanding and implementation.
4. Once approved, the written change(s) will be included in this site-specific WP addendum and other site plans as needed.

While SOW changes are typically initiated by either CEHNC or EODT project management personnel, any EODT employee can recommend a change in site operations by identifying the proposed change to the SUXOS. The SUXOS will then discuss the recommendation with the EODT PM and the CEHNC OSS and determine the extent of change required and the benefits associated with the change. If the proposed change is both feasible and beneficial to the customer, the CEHNC and/or the safety of site operations, the recommendation and its justification will be forwarded to the CEHNC KO.

(This space intentionally left blank)



CHAPTER 2: UXO OPERATIONAL PLAN

2.0 INTRODUCTION

This site-specific UXO Operational Plan details the technical approach, organizational structure, personnel responsibilities, and operational procedures to be employed by EODT at the SEDA OBG to meet the SOW objectives. This site-specific UXO Operational Plan further describes the individual activities to be conducted by EODT during each OBG task, and outlines the methodologies to be employed to accomplish the OE removal activities.

2.1 PROJECT ORGANIZATION

The SEDA OBG project team consists of the CEHNC PM (Fred Wissel), the CEHNC Project Engineer (Kevin Healy), the OSS (to be determined), the EODT PM (Bill Pearse), and the EODT SUXOS (Salvatore Molle). Figure 2-1 depicts the generic project organization, and shows the key personnel generally responsible for accomplishing project tasks.

2.2 EODT PERSONNEL RESPONSIBILITIES

(No site-specific changes to this paragraph required. Refer to the SEDA Generic WP.)

2.2.1 Program Manager

(No site-specific changes to this paragraph required. Refer to the SEDA Generic WP.)

2.2.2 Project Manager

Mr. Bill Pearse, the EODT PM, is a registered Professional Engineer with substantial experience in the management of USACE projects, including site characterization, sampling and removal projects. Mr. Pearse has completed the OSHA General Site Worker and Supervisor Training Requirements for Hazardous Waste Operations IAW 29 CFR 1910.120, and has over 12 years of experience in project planning, design, implementation and management. As the project PM, Mr. Pearse will:

- Report directly to the EODT Director of Operations for all project and operational matters;
- Manage the funding, manpower and equipment necessary to conduct site operations;
- Act as the point of contact for and communicate with the CEHNC PM;
- Oversee the overall performance of EODT individuals assigned to each project site;
- Review each SEDA SOW to ensure necessary elements are addressed in project plans; and
- Coordinate all contract and subcontract work and control contractual costs and schedules.

(This space intentionally left blank)

FIGURE 2-1. PROJECT ORGANIZATION

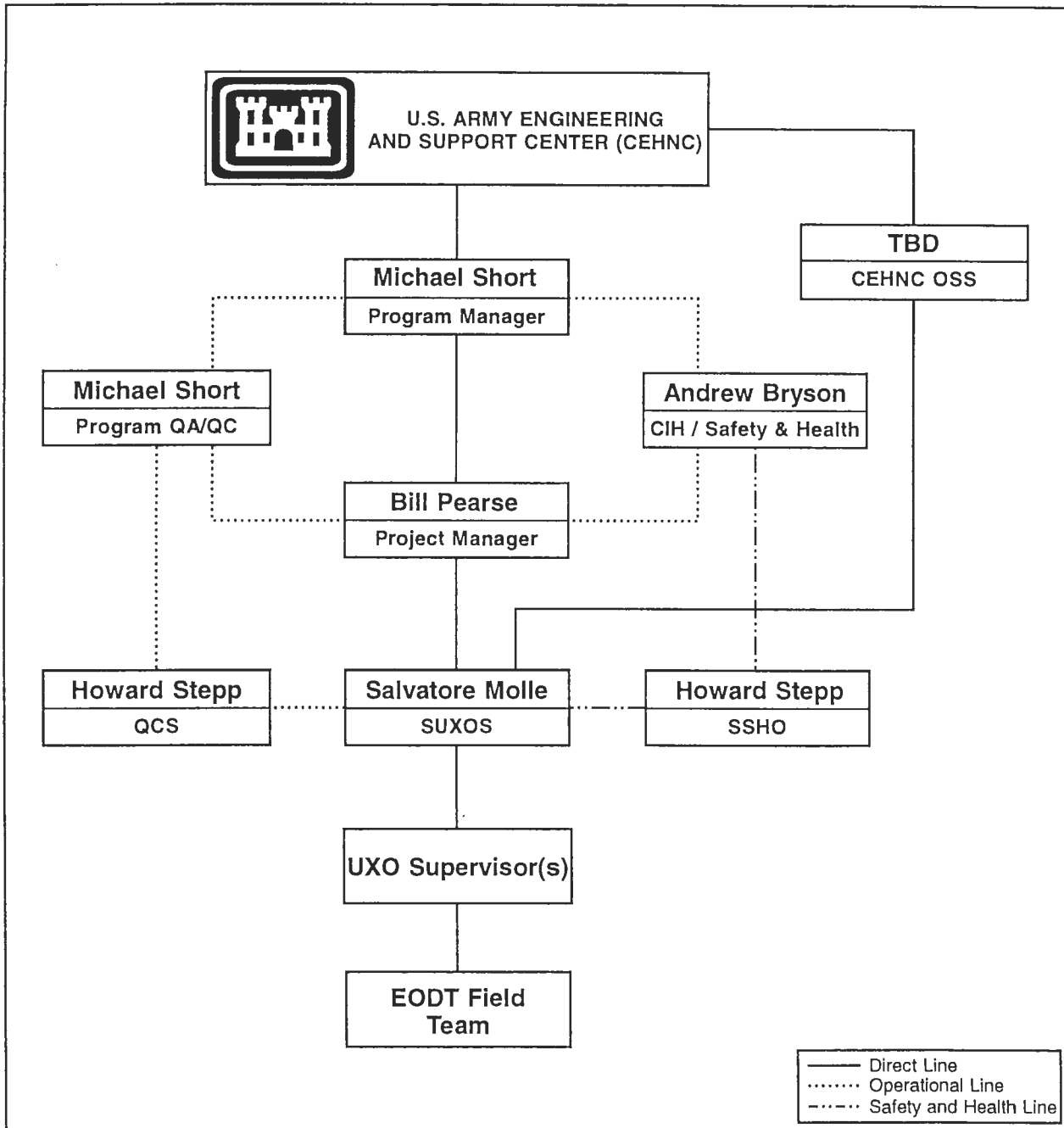

2.2.3 Senior UXO Supervisor

Mr. Salvatore Molle will be the SUXOS for this project. As the SUXOS, Mr Molle will be responsible for the on-site management of all ordnance and non-ordnance related operations. Mr. Molle is a master EOD technician and a graduate of the Basic and Advanced Naval EOD School, Indian Head, Maryland. Mr. Molle has over 18 years combined military and civilian EOD experience, and has met the CEHNC training and experience requirements specified in Data Item Description (DID) OT-0025 for the SUXOS position. He has also successfully met the 1910.120 hazardous waste training requirements. As the SUXOS, Mr. Molle will:

- Manage the EODT on-site manpower and equipment necessary to execute the SOW;
- Identify problem areas, and coordinate with the EODT PM to institute corrective measures;
- Ensure that all site activities are conducted according to this generic WP, the attached site-specific addendum, and all relevant Federal, state and local regulations;
- Act as the lead technical consultant for all on-site OE related matters; and
- Interface directly with, and relay concerns to, the OSS.

2.2.4 Occupational Safety and Health Manager

(No site-specific changes to this paragraph required. Refer to the SEDA Generic WP.)

2.2.5 Site Safety and Health Officer/Quality Control Specialist

Mr. Howard Stepp will be the combined SSHO for this project. However due to the size of the field crew, and IAW CEHNC guidance, Mr. Stepp will also be assigned to the role of QCS. In this dual capacity, Mr. Stepp will dedicate at least 50% of his time to site safety and health. Mr. Stepp is a graduate of the Basic and Advanced Naval EOD School, Indian Head, Maryland, with over 10 years combined military and civilian EOD/OE experience in OE clearance operations and supervising people. Mr. Stepp has the documented training, knowledge, and experience to perform as the SSHO/QCS, and in these roles, he will:

- Authorize "STOP WORK" orders for safety and health reasons;
- Identify and evaluate any known or potential safety problems and implementing any necessary safety-related corrective actions;
- Coordinate with the SUXOS for the implementation of safety and health requirements in the Site-Specific Safety and Health Plan (SSHP);
- Ensure that all site activities are conducted IAW this WP and other relevant regulations; and
- Ensure the implementation of the QC requirements outlined in Chapter 9 of the WP.

2.2.6 Quality Control Manager

(No site-specific changes to this paragraph required. Refer to the SEDA Generic WP.)



2.3 APPROACH AND OPERATIONAL SEQUENCE

2.3.1 General

(No site-specific changes to this paragraph required. Refer to the SEDA Generic WP.)

2.3.2 Project Operational Sequence

EODT will perform site operations at the OBG in a systematic manner using proven operating techniques and methods. EODT's experience indicates that the SOW tasks can be concluded in six phases. These phases are outlined below and are discussed in detail in paragraphs 2.4 to 2.8.

PHASE 1 - PERFORM SITE VISIT AND RECORDS REVIEW

- This task was conducted during a previous mobilization.

PHASE 2 - PRE-MOBILIZATION

- Procure, package, and ship equipment to the site;
- Coordinate with subcontractors to ensure availability of subcontractor personnel and equipment, and schedule mobilization of same; and
- Coordinate with installation and local agencies via telephone.

PHASE 3 - MOBILIZATION

- Mobilize personnel and remaining EODT equipment to the site;
- Conduct site-specific and public relations training; and
- Conduct final coordination with installation and local agencies.

PHASE 4 - SOIL EXCAVATION AND SCREENING FOR OE

- Complete the magnetometer-assisted surface clearance initiated previously, including anomaly investigation, scrap, and ordnance-related scrap (ORS) removal, and OE disposal;
- Excavate, screen, and remove OE from the berms, burn pads, low-lying hill and other site areas according to the levels of lead contamination specified below and in the SOW;
 - a. Case I - Soils containing greater than 800 milligrams lead per kilogram (mg/kg) soil;
 - b. Case II - Soils containing less 800 mg/kg but greater than 500 mg/kg;
 - c. Case III - Soils containing less than 500 mg/kg lead;
 - d. Remove and screen the top one foot of soil from the remaining areas of the OBG to remove excess debris in preparation of the geophysical survey;
- Stockpile screened soils and oversized materials according to contamination levels; and
- Sort and segregate oversize material, to include the removal and disposal of hazardous OE.

PHASE 5 - GEOPHYSICAL SURVEYING AND MAPPING

- Conduct location surveying and mapping (LS&M) of the site to re-establish the boundaries and lay in the geophysical survey grids; and
- Conduct geophysical surveying and mapping (GS&M) to locate subsurface anomalies, including the production of two dimensional maps indicating the location of the anomalies.

PHASE 6 - SUBSURFACE OE REMOVAL

- Using the Whites XLT and the Schonstedt, reacquire anomalies located by the geophysical survey and conduct a subsurface OE clearance of the entire 30-acre site;
- Using shovels and other hand tools, excavate, investigate and identify all anomalies;
- Perform explosive demolition disposal for all hazardous OE; and
- Remove any remaining ORS.

PHASE 7 - PROJECT CLOSE-OUT

- Turn in all inert OE and OE-related scrap greater than 1 inch in any dimension to the nearest Defense Reutilization Marketing Office or local scrap dealer;
- Break down site and close accounts;
- Remove/return equipment as needed and demobilize workforce; and
- Generate the Final Removal Report.

2.3.3 Project Assumptions

The planned sequence of events at the OBG, along with the timely completion of the SOW, are predicated on certain assumptions, to include:

- All surveying required to identify the lead contamination soils for excavation (including identifying specific locations by case type), together with testing and stabilization of lead-contaminated soils will be done by others, with CEHNC oversight and approval;
- Decontamination of heavy equipment, to include excavation and screening equipment, will be done at decontamination (decon) pad provided by an USACE contractor, with equipment decon to be conducted by EODT or an EODT subcontractor;
- EODT will not be required to backfill excavated areas; and
- Stockpile area will be established and maintained by another COE contractor.

2.4 PRE-MOBILIZATION

(No site-specific changes to this paragraph required. Refer to the SEDA Generic WP.)

2.5 MOBILIZATION

(No site-specific changes to this paragraph required. Refer to the SEDA Generic WP.)



2.6 REMEDIATION

2.6.1 General Site Organization and Practices

After mobilization activities, EODT will initiate OE removal operations to meet the SOW for the project. Anticipated team compositions for the SEDA are presented in Table 2-1. The subparagraphs presented below describe the work practices and technical approach that EODT will follow during OE removal operations. All operational activities at SEDA will be performed under the supervision and direction of qualified UXO personnel. Non-UXO qualified personnel will be prohibited from entering work areas, or performing any operation, unless they are accompanied, and supervised, by a UXO technician. Throughout the entire operation, EODT will strictly adhere to the following general practices.

- 1) **Work Hours:** Operations will be conducted only during daylight hours, which is thirty minutes after sunrise until thirty minutes prior to sunset. EODT intends to work four 10-hour days, with five 8-hour days as an option. In no case will personnel work more than ten hours in any day, or more than forty hours in any week, and personnel will have a minimum 48-hour rest prior to the start of the next work week.
- 2) **Site Access:** EODT will control access into work areas and will limit access to only those personnel necessary to accomplish the specific operations, or to those personnel who have a specific purpose and authorization to be on the site. No hazardous OE operations will be conducted when unauthorized personnel are in the vicinity.

TABLE 2-1: TEAM COMPOSITION

TEAM	LABOR CATEGORY	QUANTITY
Pre-Mobilization Team	PM	1
	SUXOS	1
Pre-mobilization Total		2
OE Remediation	SUXOS	1
	SSHO/QCS*	1
	UXO Supervisors	1
	UXO Specialist	5
	Subcontractor Personnel	5
Remediation Team Total		13
Close-out Team	PM	1
	SUXOS	1
	SSHO/QCS*	1
	UXO Supervisors	1
Close-out Team Total		4

* - These positions will be filled by the same person since fewer than three teams and fewer than 15 personnel are assigned to OE removal operations.

- 3) **Handling of OE:** OE items will be handled by qualified UXO personnel only. Non-UXO personnel will be closely supervised and instructed not to handle any OE or items that have the potential to be OE. For non-UXO personnel a strict “no touch” rule shall be in effect where no potential OE items will be touched by non-UXO personnel until it has been inspected and found to be ORS and free of explosive hazards.

2.6.2 Compliance with Plans and Procedures

(No site-specific changes to this paragraph required. Refer to the SEDA Generic WP.)

2.6.3 Safety and Operational Training and Briefings

(No site-specific changes to this paragraph required. Refer to the SEDA Generic WP.)

2.6.4 Preparation of Work Areas

(No site-specific changes to this paragraph required. Refer to the SEDA Generic WP.)

2.6.5 Location Surveying and Mapping

EODT will conduct LS&M within the OBG site after all of the soil excavation and screening has been completed. The LS&M will be done to re-establish the site boundaries and grids prior to the conduct of the GS&M. A magnetometer check will be made at each location where a stake or other marker is to be set to ensure the location is free of anomalies.

2.6.6 Visual Survey

EODT UXO teams will complete a magnetometer assisted visual survey of the site prior to the initiation of soil excavation and screening. This will be conducted by initially establishing a search line along one of the grid borders, with search personnel in a line spaced at a double arms length interval. Once the interval is established, personnel will advance to the other end of the grid while searching the surface for visible signs of OE. Upon completing a sweep pass, the team will then turn around, move over, and proceed as above in the opposite direction until reaching the original base line. This process is repeated until the grid is completed. Any potential OE encountered will either be inspected immediately or it may be marked with two crossed pin flags. Suspect OE will be inspected and identified and the hazard level associated with each item will be ascertained. Hazardous OE will either be blown-in-place (BIP) or it may be consolidated with other OE for disposal if the item is unfuzed and identified as safe to move.

2.6.7 Vegetation Removal

No additional vegetation removal is anticipated for this project.

2.6.8 OE Magnetometer Survey

A stand-alone magnetometer survey to locate anomalies will not be conducted during this project. Magnetometers will be used to assist UXO personnel during the surface clearance and to reacquire anomalies during the subsurface OE clearance following the GS&M. This clearance will use maps produced by GS&M. Magnetometer use for the visual survey has been described previously in paragraph 2.6.6, while magnetometer use for the reacquisition of anomalies is described in paragraph 2.6.10. Magnetometers will be response tested IAW the procedures outlined in the Quality Control Plan presented in Chapter 8 of this WP addendum.

2.6.9 Geophysical Investigation

GS&M will be conducted at the OBG to locate potential OE hazards. The procedures and technical approach for the GS&M is presented in Chapter 4.0 of this WP addendum.

2.6.10 Anomaly Investigation for Subsurface Clearances

Investigation of anomalies will be performed IAW the CEHNC Safety Concepts and Basic Considerations for Unexploded Ordnance (UXO) Operations, the procedures outlined in this WP, and the applicable EODT Standard Operating Procedures (SOPs) presented in Appendix G of this WP addendum. Prior to the initiation of anomaly investigation, a public withdrawal distance (PWD) of 1,181 feet will be established around the areas being investigated. At no time will unauthorized personnel be allowed inside the PWD while OE investigation operations are being conducted. The 1,181 PWD has been established by the CEHNC for the 37mm high explosive round which has been determined to be the most probable munition (MPM) for the OBG. While other OE may also be encountered, the 37mm has the greatest fragmentation distance and is designated as the MPM.

2.6.10.1 Subsurface Clearance

Anomaly relocation and investigation will be conducted using the dig sheets and maps derived from the GS&M, along with ferrous and non-ferrous metal detectors and appropriate hand tools. When an anomaly has been located, it will be excavated by hand using a shovel or other appropriate hand tools. Periodically during shovel digging, a Schonstedt 52 CX or the Whites XLT will be used to determine the approximate depth of the anomaly, based on the signal strength. Digging will continue with the shovel until it appears that the anomaly is within one foot of the surface. Hand digging with hand trowels or other such tools will then commence until the item is uncovered. In the event that an anomaly is determined to be at a depth greater than two feet, as specified in the SOW, the CEHNC OSS will be notified and the anomaly will be checked to determine its identity. Magnetometers used for this operation will be response checked IAW the procedures outlined in Chapter 8 of this WP addendum.



2.6.10.2 Location Recording

(No site-specific changes to this paragraph required. Refer to the SEDA Generic WP.)

2.6.10.3 Records

(No site-specific changes to this paragraph required. Refer to the SEDA Generic WP.)

2.6.10.4 Removal and Disposal of Scrap Metal

(No site-specific changes to this paragraph required. Refer to the SEDA Generic WP.)

2.6.11 Disposal Operations

2.6.11.1 General Procedures

EODT will dispose of explosively hazardous OE weekly, unless an alternate schedule is needed, and this altered schedule is approved by the CEHNC OSS. All hazardous OE will be disposed of by detonation utilizing standard demolition procedures as outlined in TM 60A-1-1-31 and the EODT Disposal/Demolition Operations SOP found in Appendix G of the generic WP. During demolition-related operations, the number of personnel remaining on site will be limited to only those personnel needed to safely and efficiently prepare the item(s) for destruction.

Demolition operations, will be performed under the direction and supervision of the SUXOS, and will be observed by the SSHO who will be present at the disposal site. The SUXOS is charged with the responsibility of ensuring that the demolition procedures contained and referenced in this WP are followed at all times. Both the SUXOS and the SSHO will monitor compliance with the safety measures and in the event of a noncompliance, both are vested with the authority to immediately halt operations. Disposal activities are inherently hazardous and require strict adherence to approved safety and operational procedures. Violations of safety requirements during demolition operations will be grounds for immediate removal from the site and termination of employment.

2.6.11.2 Equipment

(No site-specific changes to this paragraph required. Refer to the SEDA Generic WP.)

2.6.11.3 Demolition Materials

EODT will utilize the best option of the appropriate demolition materials to control the shot and reduce the net explosive weight (NEW). Due to the variety of hazardous OE that may be encountered at SEDA, approved combinations of the demolition materials listed in Table 2-2 may be needed and used to ensure proper and complete demolition of an OE item. Department of Transportation (DOT) Class 1.3 and 1.4 explosives will be used whenever possible to minimize the risks associated with handling demolition materials, and to reduce the costs.



TABLE 2-2. POSSIBLE DEMOLITION MATERIALS

DESCRIPTION	WEIGHT	DOT CLASS	COMPATIBILITY GROUP
T-100 Green Stick	1.5 lbs	1 Part Oxidizer & 1 Part Flammable	L
Perforators	19 grams	1.4S	D
Detonating Cord	80 grain	1.4D	C
Electric Detonators	No. 8	1.4B	B
Detonator, Non-electric	No. 8	1.4B	B
Time Fuze	M 700	1.4S	S
Igniter	M2/M60	1.4S	S

The explosive classes listed above are those provided to EODT by the supplier on the product data sheets, and they reflect commercial classifications that are usually lower than US Army classifications for the same items. Additionally, the compatibility codes listed above were obtained from TM9-1300-206.

2.6.11.4 Evacuation and Site Control

Prior to initiation of demolition operations, all non-essential personnel will be evacuated outside the PWD for the item(s) being detonated. As stated previously, the PWD has been initially established as 1,181 feet, based upon the 37mm high explosive MPM. Depending on the type and number of OE items being destroyed during a given demolition shot, the PWD may be increased or decreased (with the approval of the CEHNC OSS) based on data contained in HNC-ED-CS-S-98-1, January 1998. Prior to priming of demolition charges, all avenues of ingress will be physically blocked by site personnel. Blocking of ingress routes will be coordinated with the SEDA. The SUXOS will coordinate the blocking of the main road with SEDA personnel, if required. Radio communications will be maintained among all concerned parties. Avenues of ingress will not be opened without the express permission of the SUXOS. A constant state of vigilance must be maintained by all personnel to detect any intrusion into the PWD. EODT will use the appropriate number of personnel to ensure the area is properly secured.

2.6.11.5 Explosive Acquisition, Accountability, and Transportation

EODT will supply all explosives and maintain total control of the explosives while on site IAW the company SOP found in Appendix G of this WP. Explosives will be removed from the SEDA explosive storage as required, and only the amount of explosives required for the day's operation will be issued each day. EODT will comply with the requirements listed below:

- Strict accountability of explosives will be maintained at all times. EODT will maintain explosives accountability logs, found in Appendix E of this WP, and will reconcile amounts daily.



- Only UXO qualified personnel will be issued explosives and allowed to transport explosive materials.
- All vehicles transporting explosives will be properly inspected, equipped, and placarded prior to the loading of explosives onto the vehicle.

2.6.11.6 Disposal Shots

While preparing UXO for detonation, the SSHO will ensure that the number of personnel on site is kept to the minimum required to safely accomplish the task. Authority to initiate demolition operations will rest solely with the SUXOS, who is responsible for ensuring all personnel are accounted for and have evacuated the area. The SUXOS will also ensure the area is clear and secure prior to authorizing the detonation of explosive charges. The SSHO will ensure all pertinent parties have been notified of an impending demolition shot. Prior to priming, the SUXOS will: direct all personnel not involved in the priming process to withdraw outside the PWD; ensure roadblocks are posted; ensure a minimum of three feet of soil is placed on the demolition shot (if required); and ensure the warning is sounded as required by SOP 120D of Appendix G of this WP. The priming team will then withdraw outside the PWD prior to initiating the detonation.

Should multiple OE items be encountered or if multiple UXO are consolidated into a single demolition shot, the UXO and demolition charges will be configured IAW the CEHNC guidance document entitled "Procedures for Demolition of Multiple Rounds (Consolidated Shots) on Ordnance and Explosives (OE) Sites" dated August 1998 and approved by the Army on 27 October 1998. The weekly disposal operations for those UXO identified as safe to move, will be conducted in the open detonation grounds which is located adjacent to the OBG. If multiple shots are conducted, the PWD will be recalculated and approved by CEHNC OSS.

Upon completion of the demolition shot, the SUXOS and one UXO Technician will visually inspect each demolition site. While one of these individuals performs a visual inspection of the area, the second one will stand by at a safe distance and be prepared to render assistance in the event of an emergency. Upon completion of this inspection and providing there are no residual hazards, the SUXOS will authorize the resumption of site operations.

2.6.11.7 Transporting OE and Demolition Materials

(No site-specific changes to this paragraph required. Refer to the SEDA Generic WP.)

2.6.11.8 Explosive Storage

EODT will utilize an earthen covered double igloo type magazine for the storage of demolition materials and other explosive hazards. The igloos are provided by SEDA and have been constructed to U.S. Army and DDESB standards, including lightning protection and lighting. According to

SEDA personnel, the design NEW of each magazine is 450 pounds, however, EODT does not anticipate storing more than 100 pounds NEW in either magazine. Additionally, as stated above, EODT will utilize Class 1.3 and 1.4 explosives, further reducing the explosive hazard. With the exception of the Green Stick components that will be stored in a separate controlled location, all demolition materials will be stored in one magazine. The electric and non-electric detonators and igniters will be separated from the demolition materials by a sandbag wall two feet thick that is higher than the stack of either materials. The second magazine will be used for the storage of OE items that were identified as safe to move and are awaiting demolition.

2.6.12 Soil Excavation and Screening

2.6.12.1 Overview

The EODT Mechanical Soil Screening Standard Operating Procedure (SOP) 120B presented in Appendix G of this Addendum will be used for the mechanical screening of soils at the OBG. This SOP outlines the specific methods and controls that will be used to screen soil at the OBG, and includes the engineering controls that will be used to ensure the safety of those personnel within the PWD. During screening operations, non-essential personnel will not be permitted inside a 400 foot radius of the screen (as specified by CEHNC). All soils screened from the site will be transported to a stockpile location outside the OBG.

2.6.12.2 Soil Excavation

The quantity of soil to be excavated is approximately 63,000 cubic yards, and includes the soils to be excavated from the berms, burn pads, low-lying hill, other contaminated areas and a one foot lift to be removed from the entire site. The break down of soils to be sifted is as follows:

- Case I soils [containing >800 parts per million (ppm) of lead] comprise approximately 16,000 cy, located in multiple areas;
- Case II soils (containing between 500 and 800 ppm of lead) comprise approximately 2,000 cy, located in multiple areas; and
- Case III soils (containing <500 ppm of lead) comprise the remainder of the volume, located in multiple areas.

Soils will be excavated and screened by cases, from the most contaminated case to the least contaminated case, and all equipment will be decontaminated between cases, with the decontamination to be done at a decontamination pad provided by another COE contractor. The pads and berms contain approximately 11,000 cubic yards (cy) of clean and lead-contaminated soils, while the low-lying hill contains approximately 6,000 cy of clean and lead-contaminated soil. Due to the requirement to remove all lead-contaminated soil, regardless of depth, some locations within the berms and pads will require excavation down to a maximum depth of 8 ft. The safety and health



procedures that will be used for the protection of site personnel involved in the excavation of soils are presented in the site-specific SSHP presented in Appendix A to this WP Addendum.

2.6.12.3 Soil Screening

As a part of the OE removal and characterization at the OBG, the sub-tasks discussed below shall be performed in the OBG.

1. The OBG burn pads, pad berms and the low-lying hill will be excavated and screened to remove hazardous OE and scrap that is greater than 20mm in size. The sifted soils will then be stockpiled outside the OBG where it will be treated as part of a follow-on hazardous and toxic waste (HTW) remediation project.
2. Areas between the pads which have been determined to contain lead-contaminated soils, will be excavated to the depths required (minimum of three feet) and sifted for OE. This excavation will be performed in multiple lifts: the first lift will be to a depth of 1 foot, with each lift excavated thereafter being in one foot thicknesses until the lead contaminated soils have been removed. Records of what OE was located, and at what depth it was located, will be kept for later use in characterizing the subsurface OE contamination.
3. After the existing burn pads, berms, low-lying hill and other lead contaminated areas have been excavated, the entire thirty-acre OBG site will be excavated to a depth of 12 inches. The soil from this excavation will be sifted to remove debris and potential OE. This layer is being excavated to remove the soil layer that has previously been shown to interfere with geophysical surveying at the site. Following the removal and sifting of the top 12 inches, the thirty-acre site will be geophysically mapped, and all anomalies to a depth of two feet will be investigated and removed, as may be allowed by an absence of bedrock. Anomalies that are deeper will be chased and removed as well, as allowed by an absence of bedrock.
4. The areas left underneath the existing pads after removal of the one foot of soil will be geophysically mapped as part of the overall geophysical survey. If the removal of one foot of soil removes the interference in the pads as well, then anomaly investigation within the pad areas will also be performed to two feet. If the one-foot removal does not remove all interference (i.e. the pads contain OE and OE-related scrap to greater depths than the surrounding soils), then additional excavation will be done on the pads until interference is removed, and geophysical mapping and anomaly investigation can be performed. Records of what OE occurred and at what depth will be kept for later use in characterizing the subsurface contamination.

2.6.12.4 Operational Controls for Screening and Excavation

To ensure the safety of personnel involved in the excavation and screening processes, safety observers and excavation equipment operators will be protected by 3-inch plexiglass shields. The plexiglass will be installed on the excavator windshield and other cab windows, and the observers

will be placed behind the plexiglass mounted to a blast shield as outlined in SOP 120B in Appendix G of this WP Addendum. In addition, the excavation observer will be located at least 19.4 feet from the excavation, and the screen observer on the lift will be located at least 19.4 feet from the screen. This distance requirement is needed to move personnel outside the K24 over pressure zone. Since the excavator operator will be moving in and out of the K24 distance, the excavator operator will also wear hearing protection. To facilitate the excavation and screening of the soil, the screening unit is mobile and will be stationed as needed in various areas of the OBG. The actual locations of the screening unit will be agreed upon by EODT and the CEHNC OSS.

2.6.12.5 Contamination Characterization

All of the sampling data gathered from the screening, mapping and anomaly investigations data will be compiled to draw conclusions on the existence or non-existence of OE contamination below the three foot depth. Conclusions will be drawn regarding the existence of OE-contamination below the one, two and three foot depths IAW the procedures outlined below.

1. If OE-contamination does not exist below the 16 inch depth horizon, release of the site for unrestricted use from an explosives safety standpoint (even though the planned land use is to be restricted to surface recreation) will be sought. This request will be based upon the following:
 - a. The 12 inch clearance over the majority of the site is expected to show that all OE is located at less than that depth. For example, if OE is only found in the top six inches, it is reasonable to assume a 1-foot removal was adequate;
 - b. The soil sifting to depths of three feet (or more) in selected areas of the site is expected to show that no OE is present at a depth greater than 1 foot; and
 - c. Mapping and anomaly sampling of areas deeper than 1 foot is expected to show that no OE is present at a depth greater than that 1-foot horizon. At such a point, it will be concluded that no additional ON clearance will be required over the remainder of the site. This conclusion will be presented in the Final Report for this project, which will be distributed for review.
2. If OE-contamination does exist below the 1-foot depth, it will be removed. The combination of removals (sifting to 1 foot and mapping/anomaly investigation to an additional 2 feet) will provide a clearance depth of 3 feet. If all of the lead contamination has been removed, then DDESB will be petitioned to allow this site to be transferred for Public Access. If the lead contamination has not been removed, a clean soil cover will be placed over the entire thirty acres to achieve the required 4-foot "Public Access" default depth. This recommendation will have been based upon the following:



2.6.13 Quality Control Inspections

EODT will utilize the QC procedures presented in Chapter 8 of this WP for controlling and measuring the quality of all work performed at SEDA. All QC activities will be performed and documented IAW applicable professional and technical standards, USACE requirements, and project goals and objectives. All site activities and project deliverables will be assessed, documented and reviewed for precision, accuracy and completeness.

2.7 PROJECT CLOSE-OUT

(No site-specific changes to this paragraph required. Refer to the SEDA Generic WP.)

2.8 PROJECT SUBMITTALS

(No site-specific changes to this paragraph required. Refer to the SEDA Generic WP.)

(This space intentionally left blank)



CHAPTER 3: SITE-SPECIFIC SAFETY AND HEALTH PLAN

(No site-specific changes required for this Section. Refer to the SEDA generic WP for data related to this Section.)

(This space intentionally left blank)



CHAPTER 4: GEOPHYSICAL EQUIPMENT PLAN

4.0 INTRODUCTION

One of the tasks associated with the OBG OE removal SOW is the performance of a high resolution geophysical survey and investigation of the entire 30-acre site. This geophysical survey is being conducted to locate ferrous and non-ferrous anomalies with the potential for being hazardous OE. During a previous mobilization a geophysical prove-out test was conducted to test the geophysical survey equipment to be used, and the process by which data will be collected and analyzed. This test was conducted against known and unknown sources located within a prove-out grid. This prove-out was conducted to ensure that the geophysical survey equipment and procedures would adequately detect the anomalies and to ensure that the results meet the objectives outlined in SOW. During this prove-out, it was determined that significant metallic clutter permeated the top 12 inches of the soil, thereby making detection of anomalies practically impossible with any type of metal detecting instrument. EODT then removed the top one foot of soil from the test plot and re-surveyed the test plot. It was determined that the GS&M required by the SOW would be conducted only after the top one foot of soil has been removed from the site and screened. To perform the geophysical survey, EODT will use an EM-61 coupled with a data logger and navigational equipment. This system was tested and approved previously after the results of the geophysical prove-out test were assessed for adequacy by the CEHNC.

4.1 FIELD PROCEDURES

4.1.1 Search Lanes

Once the site has been divided into 200 by 200 ft grids, the geophysical survey team will lay out the search lanes within each grid just prior to surveying the grid. There will be 40 lanes 5 ft wide, adjacent to one another, running parallel to the east/west boundary line of the grid. To lay out the search lanes, the survey team will lay out pre-marked base lines along the north and south boundary lines, then lay out cones between the 5-ft marks on both base lines.

4.1.2 Geophysical Survey

The geophysical survey will be performed by two personnel, with one being a UXO specialist. While one team member travels the EM-61 along a grid lane, the other team member will record data, and if possible, mark each object or anomaly with a pin flag. Once the EM-61 has traveled to the opposing base line, the operator will shift it to the next lane and travel the instrument back to the original base line. This process will be repeated until all lanes have been searched. During the geophysical sweeps, data related to instrument position and sensor readings will be electronically recorded for processing IAW paragraph 2.8.5 of this WP addendum.



4.1.3 Equipment

The equipment to be utilized for this activity includes:

- Geonics EM-61 High Resolution Metal Detector;
- Wooden stakes or traffic cones and colored pin flags;
- Miscellaneous common hand tools; and
- Forms and logbooks to record activities.

4.2 DATA REDUCTION

General Requirements. During the geophysical survey, four separate measures are implemented to produce reliable data useful for the detection and characterization of subsurface OE:

- Sensor Drift Calculation
- Sensor Reading Calibration
- Diurnal Magnetometer Data Collection
- GPS Base Station Data Collection

Sensor Drift Calculation. Each field magnetometer or metal detector has a distinct base line [or direct current (DC)] reading level. This DC level will be measured each day over the same 30-ft length (approximately) area in the same deployment pattern. Data collected from this drift calibration run will be collected and downloaded to the field processing center for review, drift calculation, and documentation. The drift values are used in subsequent processing to level the sensor array.

Sensor Reading Calibration. Each field magnetometer or metal detector makes an accurate measurement of the earth's magnetic field to an accuracy of 0.05 nanoteslas (or gamma.) In order to determine if the sensor is operating properly, a daily sensor calibration check will be performed on each instrument, with the data applied to the geophysical survey.

Data Storage and Initial Reporting Methods. Initial data storage will be internal to the EM-61 console while in the field. This data will be transferred, using vendor supplied software, to a computer hard drive at least twice per day, to ensure minimal data loss in the event of equipment failure. Once data has been transferred, it will be checked for completeness and integrity, then backed up to further prevent data loss. All survey and mapping data shall be represented in State Grid Plane coordinates and provided to CEHNC as a delimited ASCII file in ADF format (x,y,z) and the analysis results in a ".grd" file format for use by MGE Modeler or MGE Grid Analysis tools.

Data Processing Corrections and Analysis. Standard data processing and analysis techniques will be utilized to detect, locate, and characterize anomalies recorded during the survey. Data processing will consist of three main steps; (1) corrections, (2) interpolations, and (3) filtering. Data correction processing steps include the subtraction of the diurnal drift data and application of sensor drift



values. Data interpolation is performed to generate a two-dimensional map representation of the survey data. Each processing and interpolation step is executed in a controlled manner, with all computer parameters established in files that are saved for subsequent review and verification.

After the data are interpolated, they are presented to the operator for review. This review consists of a visual inspection of the data using the Intergraph Geographical Information System (GIS), or equivalent. Data are either accepted as being suitable for analysis, rejected as being improperly processed, or conditionally accepted as requiring filtering for signal enhancement.

Digital filters are applied to the data as needed to mitigate effects of noise that may obscure anomalies that are potential OE targets. Sources of noise may include: magnetic soils and/or bedrock; effects for man-made structures such as fences and building; underground utility lines such as water pipe and conduits, and system noise associated with data dropouts. A standardized set of filters is available to apply to the data. The selection of the particular filter is documented and saved in a system file for subsequent quality control.

Targets are detected in a two-phase process. First, an automatic threshold detection method is applied to the data to identify the targets that have anomaly readings that exceed a pre-determined signal strength. The threshold level is established during the Geophysical Prove-out test, and set to allow the detection of the weakest signals associated with the suspected OE targets. The threshold detection alone is not sufficient for target detection at an OE site. Many targets of interest can fall below the pre-established threshold due to site and target-specific conditions. Additionally, the threshold method generally causes several obvious false alarms. The second phase of the target detection process is a visual inspection of all data by a trained operator with at least 2 years experience in the review of geophysical data for OE detection.

After all targets have been detected, each target will be characterized in terms of its predicted weight and depth. A three-step method will be used for this process. First, each target will be run through a dipole modeling procedure that determines the size, orientation, and location of the best fitting magnetic dipole that matches the observed data. The size is converted to a weight estimate through an empirically derived formula. Second, the data are correlated against a database of known signatures of previously excavated targets. The result of this process is an estimated target size and depth. Third, these parameter estimates are provided to a trained operator, via the GIS, for acceptance, rejection or modification.

EODT shall perform the initial threshold analysis of the data with the OE-GIS tools. Anomalies will be identified with a standard symbol and unique codes as a layer in the CADD file, with coincident raster display of the analysis stages using the OE-GIS tools. Additionally, EODT will tabulate all



anomalies into the GIS data base with a posting for data representation in an Excel spreadsheet. This data will then become the basis for the excavation and removal of suspect anomalies.



CHAPTER 5: EQUIPMENT PLAN

5.0 GENERAL

(No site-specific changes were required for this paragraph or paragraphs 5.1 through 5.15.. Refer to the SEDA Generic WP for information related to those paragraphs of this plan.)

5.16 PROJECT REQUIRED EQUIPMENT AND SUPPLIES

The services, equipment, and supplies listed in Tables 5-1 through 5-4 will be required for the OE removal action at the SEDA OBG.

TABLE 5-1: OFFICE EQUIPMENT

DESCRIPTION	QUANTITY	REMARKS
Answering machine	1 each	
Battery charger	10 each	radio
Battery charger	1 each	for vehicle batteries
Billboard system	1 each	
Blood borne pathogen kit	1 each	
Bolt cutters	1 each	
Burn kit w/burn blanket	1 each	
Calculator	1 each	
Cellular telephone	1 each	
Computer	1 each	
Copier	1 each	
Eye wash kit/15 gal	1 each	
Facsimile machine	1 each	dedicated phone line
Filing cabinet	1 each	lockable 4 drawer
Fire extinguisher	1 each	20 A:B:C
First aid kit	1 each	Large wall mounted unit
Pencil sharpener	1 each	
Printer	1 each	laser
Radio, hand held	1 each	w/base station and antenna
Telephone	2 each	
Thermometer	1 each	outside
Typewriter	1 each	
White Board	1 each	



TABLE 5-2: FIELD EQUIPMENT

DESCRIPTION	QUANTITY	REMARKS
Airborne Particulate Monitor	1 each	Real-time, direct reading
APV, Explorer	1 each	Four wheel drive, 4 door
Camera	1 each	digital
Cellular telephone	2 each	
Blood borne pathogen kit	1 each	
Brushes, long handle	2 each	equipment/personnel decon.
Buckets, plastic	12 each	five gallon
Burn kit w/burn blanket	2 each	1 each - support and exclusion zones
Calibrator	1 each	Calibration of sampling pumps
Camcorder	1 each	
Demolition kit	1 each	Blast machine, galvanometer and firing wire
De-watering pump	1 each	on call as required
Drums	1 each	PPE disposal
Explosive Day Box	2 each	
Explosive magazines	2 each	GFE
Eye wash kit	1 each	Vehicular
Fire extinguisher	2 each	10 A:B:C
Fire extinguisher	2 each	20 A:B:C
First aid kit	2 each	1 each - support and exclusion zones
Gas can with funnel	2 each	1 gallon-OSHA approved
Hard hats	4 each	
Ice chest	1 each	Coleman
Jumper cables 4 gauge	1 each	
Igloo drink cooler	2 each	5 gallon for water/gatorade
Magnetometer	3 each	Schonstedt 52 CX
Newton Pad	1 each	
Port-A-John	2 each	
Power washer, portable	1 each	equipment decontamination
Probe	4 each	12" wood/alum



TABLE 5-2: FIELD EQUIPMENT (continued)

DESCRIPTION	QUANTITY	REMARKS
Project signs		
Radio, hand held	3 each	1 each GFE
Roll on/off	1 each	ORS container
Safety glasses	8 pair	
Sampling pumps, personal	2 each	Breathing zone sampling
Shovel	2 each	pointed, long handle
Sledge	1 each	3 lb
Sound level meter	1 each	
Stretcher	2 each	
Siren Banshee	1 each	
Tape	1 each	300 foot
Tool kit	1 each	one per vehicle
Tool kit	1 each	large
Trowel/garden	2 each	
Trash cans	2 each	30 gallon
Tubs	6 each	4 Lg. shallow, 2 small, shallow

(This space intentionally left blank)



TABLE 5-3: FIELD AND OFFICE CONSUMABLES

DESCRIPTION	QUANTITY	REMARKS
Broom	1 each	
Camera	4 each	disposable/35mm
Chains	2 each	for chain saw
Dust pan	1 each	
Electrician's tape	4 rolls	
Envelopes	1 box	various sizes
File folders	4 boxes	8 1/2 x 11
Gasoline	2,500 gallons	
Gloves	8 pair	work, leather
Gloves	100 pair	rubber outer
Gloves	2 box	surgical
Writing instruments	4 boxes	1 box each high lighters, markers, pens, pencils
Labels, post-it notes	1 pack of each	
Log books	1 dozen	
Mask	3 each	CPR
Note books: Surveyor / Site Logs	2 each / 4 each	
Paper: Bond / Towels / Lined	1 case / 1 case / 50 each	
Oil	2 each	for weed eater/chain saw - 6 oz
Respirators : full face	10 each	# of sizes vary based upon fit tests
Respirator cartridges	3 boxes	high efficiency particulate (HEPA)
Ruler	1 each	
Snake leggings	8 each	plastic
Stakes, Flags, String		
Stapler / staples	1 each / 1 box	
Tape - Duct	8 rolls	
Tape Scotch / Engineer	2 rolls / 2 boxes	
Tyvek suits / coveralls	10 cases	sizes will vary based upon individuals on site
Wet/handi wipes	5 containers	



TABLE 5-3: EXPLOSIVES CONSUMABLES

Description	Weight	DOT Class	Compatibility Group	UN ID No.	DOT Ex. No.
T-100 Green Stick	1.5 lbs	Oxidizer & Flammable	L	1942 & 1261	N/A
Perforators	19 grams	1.4S	D	0441	9608028
Detonating Cord	80 grain	1.4D	C	0289	9806054
Electric Detonators	No. 8	1.4B	B	0244	9104118

(This space intentionally left blank)



CHAPTER 6: LOCATION SURVEYING AND MAPPING PLAN

6.0 GENERAL

EODT will conduct LS&M within the OBG site after all of the soil excavation and screening has been completed. The LS&M will be done to re-establish the site boundaries and grids prior to the conduct of the GS&M. The LS&M conducted in support of this addendum will be performed IAW the LS&M plan included in Generic WP.

(This space intentionally left blank.)



CHAPTER 7: ENVIRONMENTAL PROTECTION PLAN

(No site-specific changes required for this Section. Refer to the SEDA generic WP for data related to this Section.)

(This space intentionally left blank)



CHAPTER 8: QUALITY CONTROL PLAN

(No site-specific changes required for this Section. Refer to the SEDA generic WP for data related to this Section.)

(This space intentionally left blank)



CHAPTER 9: WORK DATA COST MANAGEMENT PLAN

9.0 GENERAL

The purpose of this site-specific Work Data and Cost Management Plan (WDCMP) is to present the general structure of the management system EODT will use to ensure the effective management of allocated funds and manpower for the SEDA OBG OE Removal and Characterization. All site-specific work will be accomplished in order of precedence as set forth by the CEHNC in the SOW. This plan describes: the organizational structure EODT will use to manage the project; the sequence in which operations will be performed; and the projected cost by operational milestone.

9.1 PROJECT ORGANIZATION

(No site-specific changes to this paragraph required. Refer to the SEDA Generic WP.)

9.2 PROJECT DAILY SCHEDULE

A typical daily schedule is outlined below in Table 9-1:

TABLE 9-1. TYPICAL DAILY SCHEDULE

Time	Activity	Location
0700-0730	Tailgate Safety and Operations Briefing and Equipment Load Out	Field Office
0730-1030	Conduct Field Operations	Assigned Work Areas
1030-1045	Morning Break	Site Support Zone
1045-1200	Conduct Field Operations	Assigned Work Areas
1200-1230	Lunch	Field Office
1230-1530	Conduct Field Operations	Assigned Work Areas
1530-1545	Afternoon Break	Site Support Zone
1545-1700	Conduct Field Operations	Assigned Work Areas
1700-1715	Stop Operations/Return to Field Office	Assigned Work Areas
1715-1730	Clean and Store Equipment	Field Office

9.2.1 Performance Data

It is anticipated that site operations will require a total field effort of 14 weeks, to include mobilization/site set-up and site closure/demobilization. Table 9-2 illustrates the performance data for the life of the field effort.



TABLE 9-2: PERFORMANCE DATA

Activity	Acres	Grids	Cubic Yards	Work Days	Calend ar Days
Mobilization	NA	NA	NA	1	1
Location, Survey and Mapping (After removal of 1 foot lift from site)	30	33	NA	3	3
Excavation and Screening of the Berms, Low Lying Hill, Selected Locations Within the OBG and 12 inches of Surface Soils. Sort Oversize Material.	NA	NA	63,000	52	91
Geophysical Surveying/Mapping and Anomaly Relocation & Investigation	30	33	NA	44	77
Turn-in Inert OE and OE-related Scrap	NA	NA	NA	2	2
Demobilization	NA	NA	NA	1	1
TOTALS				103	175

9.3 TASK ORDER COST DATA

In developing the site-specific cost estimates, EODT used information obtained during the site visit and data from previous site activities. Prior to mobilization, EODT will make available, for CEHNC review, three price quotes for equipment and services. This is of particular importance, since EODT plans to supply materials for this program on a time and materials basis.

9.3.1 Manpower Requirements

EODT has structured its manpower requirements to meet the operational requirement of this task order. Our structure was designed to minimize associated costs (i.e., travel and per-diem), and provide an effective blend of technical talents and skills for executing the work associated with this task order. Further, EODT chose the listed labor categories to ensure that team flexibility and production rates could be met. A detailed list of manpower requirements and associated costs is contained in Table 9-3. This table breaks down the projected labor costs by labor category, and includes the number of hours and personnel assigned to each category, along with the hourly rate applied to each labor category and the cost by category.



TABLE 9-3: LABOR REQUIREMENTS AND COST

TASK 1: WORK PLAN REVISIONS				
Labor Category	Personnel Per Category	Hours Per Person	Hourly Rate	Cost By Category
Project Manager	1	24	\$71.37	\$1,712.88
CIH	1	80	\$67.23	\$5,378.40
TASK 2 TOTALS	2	100	NA	\$7,091.28
TASK 5: UXO REMOVAL				
Labor Category	Personnel Per Category	Hours Per Person	Hourly Rate	Cost By Category
Geophysicist	1	155	\$63.89	\$9,902.95
Project Manager	1	432	\$78.51	\$33,916.32
SUXOS	1	968	\$60.74	\$58,796.32
SSHO	1	484	\$50.17	\$24,282.28
UXO Supervisor	1	968	\$50.17	\$48,564.56
UXO Specialist	5	968	\$44.89	\$217,267.60
Certified Industrial Hygienist	1	72	\$73.95	\$5,324.40
Contract Administrator	1	16	\$39.63	\$634.08
Word Processor	1	48	\$30.51	\$1,464.48
TASK 5 TOTALS	13	4111	NA	\$400,152.99
TASK 6: SCRAP TURN-IN				
Labor Category	Personnel Per Category	Hours Per Person	Hourly Rate	Cost By Category
Project Manager	1	4	\$78.51	\$314.04
SUXOS	1	20	\$60.74	\$1,214.80
SSHO	1	10	\$50.17	\$501.70
QCS	1	10	\$50.17	\$501.70
UXO Supervisor	1	20	\$50.17	\$1,003.40
UXO Specialist	5	20	\$44.89	\$4,489.00
TASK 6 TOTALS	10	84	NA	\$8,024.64



TABLE 9-3: LABOR REQUIREMENTS AND COST (continued)

TASK 7: PERFORM QUALITY CONTROL				
Labor Category	Personnel Per Category	Hours Per Person	Hourly Rate	Cost By Category
QCS	1	484	\$50.17	\$24,282.28
Program QA/QC	1	8	\$73.95	\$591.60
TASK 7 TOTALS	2	492	NA	\$24,873.88
TASK 8: PREPARE & SUBMIT FINAL REPORT				
Labor Category	Personnel Per Category	Hours Per Person	Hourly Rate	Cost By Category
Project Manager	1	88	\$78.51	\$6,908.88
Certified Industrial Hygienist	1	16	\$73.95	\$1,183.20
Contract Administrator	1	24	\$39.63	\$951.12
Word Processor	1	40	\$30.51	\$1,220.40
TASK 8 TOTALS	12	168	NA	\$10,263.60

9.4 TASK AND PROJECT COSTS

Details regarding the site-specific task and project costs for the OBG are presented in Table 9-4. This table breaks down the projected labor, material and travel costs needed to meet the site-specific SOW. This table also presents the number of hours and personnel assigned to each labor category.

(This space intentionally left blank)



TABLE 9-4: TASK AND PROJECT COSTS

TASK 1 WORK PLAN REVISIONS (Fixed Price)		AMOUNT
Labor		\$10,645.27
Material		\$645.00
Travel		
	SUBTOTAL	\$11,290.27
TASK 5 UXO REMOVAL (Time and Materials)		AMOUNT
Labor		\$400,152.99
Material		\$886,049.99
Travel		\$116,571.20
	SUBTOTAL	\$1,402,774.18
TASK 6 SCRAP TURN-IN (Fixed Price)		AMOUNT
Labor		\$7,985.39
Material		\$868.78
Travel		\$1,442.00
	SUBTOTAL	\$10,296.17
TASK 7 QUALITY CONTROL (Fixed Price)		AMOUNT
Labor		\$24,873.88
Material		\$0.00
Travel		\$13,184.00
	SUBTOTAL	\$38,057.88
TASK 8 FINAL REPORT (Fixed Price)		AMOUNT
Labor		\$10,263.60
Material		\$537.50
Travel		\$0.00
	SUBTOTAL	\$10,801.10
PROJECT TOTAL		\$1,473,219.60
PROJECT CATEGORY TOTALS		
CATEGORY		AMOUNT
0006 Labor		\$10,645.27
0100 Labor		\$443,275.86
Material		\$888,101.27
Travel		\$131,197.20
PROJECT TOTAL		\$1,473,219.60

9.4.1 Government Furnished Equipment

Any GFE provided will lower the material costs.

9.4.2 Consumable Supplies

Consumable supplies consist of twine, wooden stakes, etc. A list of those items included in EODT's overhead and not directly chargeable to the project, to include exceptions and unallowable charges, are presented in Table 9-5.



TABLE 9-5. CONSUMABLES AND UNALLOWABLE CHARGES

Employee Consumables and/or Personal Equipment	
The following items are considered examples of employee consumables and/or personal equipment, and as such are not allowable direct costs, with the exception noted below:	
Goggles	Clocks
Safety Equipment	Boots
Shoes	Cups
Gloves	Work Uniforms
Bug/Insect Repellant	Office Supplies
Wet Wipes or pre-moistened towelettes	Uniform Maintenance
Paper Towels	Laundry Items
Toilet Paper	Flashlights
Bottled Water	Batteries
Rain Suits	Shovels/Rakes
Whistles/Air Horns	Water Coolers
Sun screen	Keys
Poison Ivy/Oak Protection & Cleanser	Paint
Exception: Under EODT's approved DCAA accounting system, certain items similar to those listed above may be charged as direct costs. For example, equipment and supplies which are required by the unusual or unique characteristics of a particular task, site, or locale (or which must be purchased in unusual quantities because of the above factors) may be charged as direct costs.	
Unallowable Charges (direct and indirect):	
Coffee	Ice
Tea	Shaving Equipment/Supplies
Gatorade or Sports Beverage	Soft Drinks and Milk
Sugar	Coffee Creamer

(This space intentionally left blank)

APPENDIX A
TO
ADDENDUM 1 OF THE GENERIC WORK PLAN
FOR THE
ORDNANCE AND EXPLOSIVES REMOVAL
AT THE
OPEN BURNING GROUNDS
SENECA ARMY DEPOT ACTIVITY
ROMULUS, NEW YORK
SITE SAFETY AND HEALTH PLAN

Contract Number: DACA87-97-D-0005
Task Order: 0003

Prepared For:



U.S. Army Engineering and Support Center
Huntsville, Alabama

Prepared By:



2229 Old Highway 95
Lenoir City, Tennessee 37771

June 1999



PREFACE

This site-specific Site Safety and Health Plan (SSHP) has been prepared for the United States Army Engineering and Support Center, Huntsville (CEHNC) in support of the EOD Technology, Inc. (EODT) Ordnance and Explosives Removal Action (OE RA) being performed at the Seneca Army Depot Activity (SEDA) Open Burning Grounds (OBG), located near Romulus, New York. This SSHP Addendum will identify and address the specific hazards associated with the SEDA OBG and the OE removal operations. Additionally, this SSHP addendum also addresses the work practices and procedures to be used for protecting site personnel from the hazards that may be encountered during on-site

This site-specific SSHP Addendum refers to, and will be used in conjunction with both the generic SEDA WP and the generic SEDA SSHP which have been submitted and approved previously. All activities conducted by EODT personnel at the OBG will be performed in accordance with (IAW) this site-specific SSHP Addendum, the generic WP and SSHP, and applicable U.S. Army Corps of Engineers (USACE), Federal, state, and local regulations.

In the development of this site-specific SSHP, EODT has identified the various site and task hazards that may be encountered during OBG activities. The hazard control methods detailed in this SSHP addendum were evaluated and selected to minimize the potential for personal exposure to site or task hazards, and to safeguard the environment and general public. This SSHP addendum is to be viewed as a living document and may require changes based upon actual on-site implementation of site tasks. Any changes to this SSHP addendum will be approved by the personnel on the following signature page and the CEHNC Contracting Officer (KO).



SITE SAFETY AND HEALTH PLAN APPROVAL

Project: Ordnance and Explosives Removal Action at the Open Burning Grounds

Site: Seneca Army Depot Activity

Site Location: Romulus, New York

Contract Number: DACA87-97-D-0005

Task Order: 0003

The personnel below have reviewed the attached SSHP addendum for the referenced site, and recognize that upon completion of this form, the attached SSHP will be approved by EODT for use at the referenced project site during the conduct of the tasks listed in the CEHNC Statement of Work. Changes to this SSHP will be documented and submitted in writing, approved by the EODT personnel listed below, and the CEHNC KO. Prior to the formal submission and approval of required SSHP changes, on-site implementation of the changes may occur if the personnel listed below concur and the Senior Unexploded Ordnance (UXO) Supervisor (SUXOS) receives and documents the approval of the CEHNC on-site Safety Specialist (OSS). This informal, but documented system minimizes production impact while ensuring personnel safety and health.

Reviewed by: _____
Salvatore Molle
EODT Senior UXO Supervisor

Date: _____

Reviewed by: _____
Bill Pearse
EODT Project Manager

Date: _____

Reviewed by: _____
Michael Short
EODT Director of Operations

Date: _____

Prepared and
Approved by: 
Andrew Bryson, CIH, MPH
EODT Occupational Safety and Health Manager

Date: 



TABLE OF CONTENTS

Section	Page
1.0 GENERAL	A-1
1.1 SCOPE AND APPLICATION	A-1
1.2 OBJECTIVE	A-1
1.3 SUBMISSION OF SITE-SPECIFIC ADDENDUMS	A-1
1.4 SSHP APPROVAL	A-2
1.5 SSHP MODIFICATIONS	A-2
1.6 REGULATIONS AND GUIDELINES	A-2
1.7 REFERENCES	A-2
2.0 STAFF ORGANIZATION AND RESPONSIBILITIES	A-3
2.1 ROLES AND RESPONSIBILITIES OF EODT PERSONNEL	A-3
2.1.1 Program Manager	A-3
2.1.2 Project Manager	A-3
2.1.3 Occupational Safety and Health Manager	A-3
2.1.4 Senior UXO Supervisor	A-3
2.1.5 Site Safety and Health Officer	A-4
2.2 RESPONSIBILITIES OF ALL SITE PERSONNEL	A-4
2.3 SUBCONTRACTOR RESPONSIBILITIES	A-4
2.4 CEHNC PROJECT PERSONNEL	A-5
3.0 SITE DESCRIPTION AND CHARACTERIZATION	A-7
3.1 SEDA LOCATION AND DESCRIPTION	A-7
3.2 DESCRIPTION OF THE OE REMOVAL ACTION SITE	A-7
3.2.1 Site Description	A-7
3.2.2 Previous Site Investigations	A-7
3.3 ON-SITE TASKS TO BE PERFORMED	A-8
3.3.1 Introduction	A-8
3.3.2 General On-site Tasks That May Be Performed	A-8
3.4 CONTAMINATION CHARACTERIZATION	A-8
3.4.1 Chemical Warfare Materials	A-8
3.4.2 OE Contamination	A-8
3.4.3 Hazardous Substances and Materials	A-9



TABLE OF CONTENTS (continued)

Section	Page
4.0 HAZARD ASSESSMENT AND RISK ANALYSIS	A-11
4.1 INTRODUCTION	A-11
4.2 TASK HAZARD ASSESSMENT AND EXPOSURE RISK ANALYSIS ...	A-11
4.2.1 Introduction and General Requirements	A-11
4.2.2 Hazards and Risks Associated with Potential Chemical Exposures .	A-11
4.2.3 Hazards and Risks Associated with OE Hazards	A-12
4.2.4 Physical Hazards	A-12
4.2.5 Biological Hazards	A-13
4.3 TASK DESCRIPTIONS AND HAZARDS	A-13
4.3.1 Task Descriptions	A-13
4.3.2 Mobilize and Set-up Site Operational Areas	A-14
4.3.3 Complete the Visual Sweep	A-14
4.3.4 Excavate and Screen Soil	A-15
4.3.5 Sort and Segregate Oversize Material	A-16
4.3.6 Conduct Location Surveying and Mapping	A-17
4.3.7 Conduct a Geophysical Survey	A-17
4.3.8 Investigate Subsurface Anomalies	A-17
4.3.9 Turn-in Ordnance Related Scrap	A-18
4.3.10 Perform Project Quality Control	A-19
4.3.11 Close-out the Site and Demobilize Equipment and Personnel	A-19
4.4 COMMUNICATION OF TASK HAZARD INFORMATION	A-19
4.5 EMPLOYEE RIGHT-TO-KNOW HAZARD COMMUNICATION	A-19
4.6 CERTIFICATION OF TASK HAZARD ASSESSMENT	A-19
5.0 ACCIDENT PREVENTION	A-20
6.0 TRAINING PLAN	A-21
7.0 PPE PROGRAM	A-22
7.1 INTRODUCTION	A-22
7.2 SPECIAL CONSIDERATIONS	A-22
7.3 TASK SPECIFIC ASSIGNMENT OF PPE	A-22
7.4 LEVEL D PPE	A-23
7.5 MODIFIED LEVEL D PPE	A-24



TABLE OF CONTENTS (continued)

Section	Page
7.6 LEVEL C PPE	A-24
7.6.1 Standard Level C PPE	A-24
7.6.2 Modified Level C PPE	A-25
7.7 RESPIRATOR ISSUE	A-25
7.7.1 Respirator Selection	A-25
7.7.2 Selection Criteria	A-25
7.7.3 Task-Specific Respiratory Assignment	A-26
7.7.4 Respirator Training	A-26
7.8 PPE INSPECTION, MAINTENANCE AND STORAGE	A-26
8.0 MEDICAL SURVEILLANCE	A-27
9.0 MONITORING PLAN	A-28
9.1 MONITORING RESPONSIBILITIES	A-28
9.2 MONITORING SCHEDULE	A-28
9.3 NOISE MONITORING	A-30
9.4 HEAT STRESS MONITORING	A-30
9.5 REAL-TIME MONITORING OF RESPIRABLE DUST LEVELS	A-30
9.6 PERSONAL BZ SAMPLING FOR LEAD CONTAINING DUST	A-30
9.7 MONITORING EQUIPMENT CALIBRATION AND MAINTENANCE ...	A-31
10.0 HEAT AND COLD STRESS PREVENTION	A-32
11.0 SITE CONTROL	A-33
11.1 CENTER OF OPERATIONS	A-33
11.2 PROJECT SITE ACCESS	A-33
11.3 WORK ZONE ACCESS CONTROL AND SECURITY	A-33
11.4 SITE CONTROL DURING DEMOLITION OPERATIONS	A-34
11.5 EQUIPMENT STORAGE AND SECURITY	A-34
11.6 SITE MAPS	A-34
11.7 SITE COMMUNICATIONS	A-35
11.8 BUDDY SYSTEM	A-35



TABLE OF CONTENTS (continued)

Section	Page
12.0 PERSONNEL AND EQUIPMENT DECONTAMINATION	A-37
12.1 GENERAL HYGIENE	A-37
12.2 POTABLE AND NONPOTABLE WATER SUPPLIES	A-37
12.3 SITE HOUSE KEEPING	A-37
12.4 PERSONNEL DECONTAMINATION	A-38
12.4.1 Emergency PDS	A-38
12.4.2 Level C PPE Decontamination	A-40
12.4.3 Modified Level C PPE Decontamination	A-41
12.4.4 Level D and Modified Level D PPE Decontamination	A-41
12.5 EQUIPMENT DECONTAMINATION	A-41
 13.0 ENGINEERING CONTROLS, SWP'S AND STANDING ORDERS	 A-42
 14.0 EMERGENCY RESPONSE / CONTINGENCY PROCEDURES	 A-43
 15.0 LOGS, REPORTS, AUDITS, INSPECTIONS, AND RECORD KEEPING	 A-44

(This space intentionally left blank)



ATTACHMENTS

Attachment 1 Corporate Safety and Health Program Certification

Attachment 2 Generic Certification of Task Hazard Assessment Forms

(This space intentionally left blank)



LIST OF TABLES

<u>Table</u>	<u>Page</u>
3-1 Summary of Exposure Standards and Properties for On-site Chemical Hazards	A-10
7-1 Task Specific Assignment of PPE Levels	A-23
9-1 Site Monitoring Schedule and Action Levels	A-29

(This space intentionally left blank)



LIST OF FIGURES

<u>Figure</u>	<u>Page</u>
2-1 Safety and Health Organizational Chain of Command	A-6
12-1 PDS for Level C	A39

(This space intentionally left blank)

LIST OF ACRONYMS AND ABBREVIATIONS

ACGIH	American Conference of Governmental Industrial Hygienist
BIP	blow(n)-in-place
BRAC	Base Realignment and Closure
BZ	breathing zone
CEHNC	U.S. Army Engineering and Support Center, Huntsville
CFR	Code of Federal Regulations
CIH	Certified Industrial Hygienist
COC	chain-of-command
CPR	cardiopulmonary resuscitation
CRZ	contamination reduction zone
CSHP	Corporate Safety and Health Program
CTHA	Certification of Task Hazard Assessment
CWM	Chemical Warfare Materiel
°C	degrees Celsius
DID	Data Item Description
DoD	U.S. Department of Defense
EM	Engineering Manual
EMM	earth moving machinery
EOD	explosive ordnance disposal
EODT	EOD Technology, Inc.
EPA	Environmental Protection Agency
EPDS	emergency personal decontamination station
ER	Engineering Regulation
EZ	exclusion zone
°F	degrees Fahrenheit
ft	feet
GFCI	ground fault circuit interrupter
GS&M	geophysical surveying and mapping
HAZCOM	Hazard Communication
HAZWOPER	Hazardous Waste Operations and Emergency Response
HEPA	high efficiency particulate-air
HTW	hazardous and toxic waste
IAW	in accordance with
IDLH	immediately dangerous to life or health
KO	Contracting Officer
LO/TO	Lockout/Tagout



LIST OF ACRONYMS AND ABBREVIATIONS (continued)

LS&M	location surveying and mapping
mm	millimeter
MSDS	material safety data sheet
NIOSH	National Institute of Occupational Safety and Health
OB	open burn
OD	open detonation
OE	ordnance and explosive
ORS	ordnance-related scrap
OSHA	Occupational Safety and Health Administration
OSHM	Occupational Safety and Health Manager
OSIC	On-scene Incident Commander
OSS	On-site Safety Specialist
PDS	personal decontamination station
PM	Project Manager
PPE	personal protective equipment
ppm	parts per million
QC	quality control
RA	removal action
RI	remedial investigation
ROD	Record of Decision
SEDA	Seneca Army Depot Activity
SSHP	Site Safety and Health Plan
SOP	standard operating procedure
SOW	Scope of Work
SSHO	Site Safety and Health Officer
SUXOS	Senior UXO Supervisor
SWP	Safe Work Practices
SZ	support zone
TAGM	Technical Administrative Guidance Memorandum
TWA	time-weighted average
TO	Task Order
USACE	U.S. Army Corps of Engineers
UXO	unexploded ordnance
UV	ultraviolet
WP	Work Plan
WZ	Work Zone



1.0 GENERAL

1.1 SCOPE AND APPLICATION

This Site Safety and Health Plan (SSHP) has been prepared by EOD Technology, Inc. (EODT) for the U.S. Army Engineering and Support Center, Huntsville (CEHNC) for the Ordnance and Explosives (OE) Removal Action (RA) operations to be performed at the former Open Burning Ground (OBG). This site is located within the Seneca Army Depot Activity (SEDA) near Romulus, New York.

EODT is mandated by its corporate policy to provide site personnel with the requisite training, information and resources needed to ensure that the manner in which operations are conducted safeguards site personnel from exposure to uncontrolled, recognized safety and health hazards. Due to the potentially dangerous nature of the SEDA OE operations, the SEDA generic SSHP, along with this SSHP addendum, will be applied to all EODT, subcontractor and USACE personnel who participate in on-site tasks involving exposure potential to on-site safety or health hazards.

1.2 OBJECTIVE

To ensure continued compliance with the EODT safety and health policy statement referenced above, the primary objective of this site-specific SSHP addendum is to provide personnel with the critical information they will need to safeguard themselves and fellow site personnel from the hazards associated with the OE RA at the OBG.

1.3 SUBMISSION OF SITE-SPECIFIC ADDENDUMS

This site-specific SSHP addendum has been developed from the previously submitted and approved generic SEDA SSHP. The generic SEDA SSHP was developed to present generalized information related to the site conditions, hazards and situations that historically exist at most sites within the SEDA facility. To address the site-specific site and hazard information related to a specific SOW, a site-specific SSHP is developed as a part of the Addendum to the Generic Work Plan. This site-specific SSHP utilizes the SEDA generic SSHP as a template, with additions, deletions and modifications made to each paragraph as needed to portray the actual site and task data as specified in the SOW. In the event that major additions are required for a given section, the additional paragraphs will be added to the end of the section. To clarify the other types of changes made to the generic SSHP during the development of this site-specific SSHP, the following shall apply:

- Paragraphs in this site-specific SSHP addendum with no reference to the generic SSHP replace the original text of the generic SSHP and no additional reference to the generic is required for the given paragraph;
- Paragraphs and sections of this site-specific SSHP that are unchanged from the generic SSHP are denoted using the term “(No site-specific changes required to this paragraph.

Refer to SEDA generic SSHP.)”, and the required data are therefore presented in the generic SSHP;

- Paragraphs where the text in the generic is augmented with site-specific data will have both the generic and the site-specific text presented in the paragraph; and
- Paragraphs that have been deleted from this site-specific SSHP addendum are noted as such “*(Information related to this paragraph has been deleted from this site-specific SSHP.)*.”

1.4 SSHP APPROVAL

Prior to on-site participation in OE operations, all site and project personnel shall read this Addendum and the generic SSHP carefully, understand their contents, and complete the Site-specific SSHP Review and Approval Form presented in Appendix E of the WP. Signing this form, signifies their understanding of the documents, and verifies their willingness to comply with the expressed requirements. Question related to the generic SSHP or this addendum shall be addressed and resolved by the EODT SSHO. Project activities shall be managed and implemented so as to comply with the provisions of this SSHP and the regulations and guidelines listed in Section 1.6.

1.5 SSHP MODIFICATIONS

No site operations/tasks will be performed in a manner that conflicts with the safety, health, or environmental precautions expressed in the generic SSHP or this addendum. While requirements listed in this addendum may change as site work progresses, no changes will be made without the approval of the CEHNC KO, EODT’s Project Manager (PM) and EODT’s Occupational Safety and Health Manager (OSHM). If modification must be made, the proposed changes will be developed by the EODT PM and OSHM in conjunction with the on-site Senior Unexploded Ordnance (UXO) Supervisor (SUXOS) and submitted to the CEHNC KO for approval. Upon receipt of written approval, EODT will make the necessary document modifications. If the modification involves changes to the field operations, actual field implementation of the changes may be implemented on-site if the CEHNC On-site Safety Specialist (OSS) provides documented approval of the procedural modification.

1.6 REGULATIONS AND GUIDELINES

(No site-specific changes required to this paragraph. Refer to SEDA generic SSHP.)

1.7 REFERENCES

(No site-specific changes required to this paragraph. Refer to SEDA generic SSHP.)

2.0 STAFF ORGANIZATION AND RESPONSIBILITIES

2.1 ROLES AND RESPONSIBILITIES OF EODT PERSONNEL

EODT recognizes that the effective, safe and healthful performance of site operations is primarily a function of the ability, skill and knowledge of the on-site personnel assigned to the implementation of the tasks specified in the SOW. However, the other key element to establishing and maintaining a safe and healthful work environment is the effective management of the personnel, equipment and financial resources needed to implement the safety, health and operational policies and procedures specified in this SSHP and the WP. Figure 2-1 depicts the general safety and health organizational chain-of-command (COC) that will be used to manage and control the safety and health issues related to SEDA site operations.

2.1.1 Program Manager

(No site-specific changes required to this paragraph. Refer to SEDA generic SSHP.)

2.1.2 Project Manager

Mr. Bill Pearse, the EODT PM, is a registered Professional Engineer with substantial experience in the management of USACE projects, including site characterization sampling projects. Mr. Pearse has completed the OSHA General Site Worker and Supervisor Training Requirements for Hazardous Waste Operations IAW 29 CFR 1910.120, and has in excess of 12 years of experience in project planning, design, implementation and management. As the PM for this project, Mr. Pearse will:

1. Report directly to the Program Manager for all project and operational matters;
2. Manage the funding, manpower, and equipment necessary to safely conduct site operations;
3. Review this SSHP and have a thorough understanding of its requirements;
4. Furnish copies of the WP and SSHP to site personnel for their review;
5. Coordinate with the OSHM to ensure that all anticipated project-specific safety and health issues have been addressed in this SSHP;
6. Coordinate the assignment of subcontractors and ensuring that subcontractor personnel and equipment meet the requirements of the WP and SSHP;
7. Relay safety and health concerns to the CEHNC on-site Safety Specialist (OSS); and
8. Coordinate with the OSHM to ensure site compliance with the SSHP and the CSHP.

2.1.3 Occupational Safety and Health Manager

(No site-specific changes required to this paragraph. Refer to SEDA generic SSHP.)

2.1.4 Senior UXO Supervisor

Mr. Salvatore Molle, the project SUXOS, is a master Explosive Ordnance Disposal (EOD) technician and a graduate of the Basic and Advanced Naval EOD School, Indian Head, Maryland.



Mr. Molle has over 18 years combined military and civilian EOD experience, with extensive experience as a SUXOS. He has completed the OSHA 40-hour General Worker and the 8-hour Supervisor training requirements IAW 29 CFR 1910.120. He has also completed the EODT SSHO and Site Manager training course and will be responsible for the on-site management and oversight of all EODT site operations. As the SUXOS, Mr. Molle will:

1. Conduct on-site management of the EODT manpower and equipment necessary to safely conduct site operations;
2. Review and become familiar with the generic and site-specific WP and SSHP and any other documents pertinent to the conduct of site operations;
3. Provide copies of the WP and SSHP to EODT and subcontractor personnel for their review;
4. Review the SOW and ensure that the required safety and health elements are addressed in either the generic SSHP or the site-specific SSHP Addendum;
5. Act as the lead technical consultant for all on-site OE related matters;
6. Schedule and present the operational portion of the daily tailgate safety briefing;
7. Enforce compliance with all aspects and addendums to the SSHP and WP; and
8. Directly interface with, and relay safety and health concerns to, the CEHNC OSS.

2.1.5 Site Safety and Health Officer

Mr. Howard Stepp will act as the SSHO for this project. As the SSHO, Mr. Stepp will be responsible for the overall safety of on-site personnel and the on-site management of all safety-related issues. Mr Stepp is a master EOD technician and a graduate of the Basic and Advanced Naval EOD School, Indian Head, Maryland. He has over 21 years combined military and civilian EOD experience and has completed the OSHA HAZWOPER training requirements IAW 29 CFR 1910.120. Mr. Stepp possess the requisite experience and training needed to implement the requirements of this site-specific SSHP addendum and the generic SSHP. As the SSHO Mr. Stepp will:

1. Authorize STOP WORK for safety and health reasons;
2. Implement and enforce the requirements and procedures outlined in either this generic SSHP or the site-specific SSHP Addendum;
3. Conduct daily tailgate safety briefings;
4. Conduct, or assist in, the training of site personnel in site-specific hazards and ensuring completion of the EODT documentation of training form;
5. Specify proper levels of PPE IAW the requirements of this SSHP;
6. Consult with the EODT OSHM prior to downgrading levels of PPE;
7. Develop and submit for approval additional safety and health procedures, as required;
8. Implement and enforce the EODT Alcohol/Drug Abuse Policy;
9. Investigate injuries, illnesses, accidents, incidents and near misses;
10. Conduct visitor orientation;



11. Conduct, and document, daily safety inspections and weekly safety audits;
12. Coordinate with the EODT OSHM on monitoring and PPE requirements;
13. Conduct monitoring IAW this SSHP; and
14. Ensure field implementation of the EODT CSHP.

2.2 RESPONSIBILITIES OF ALL SITE PERSONNEL

(No site-specific changes required to this paragraph. Refer to SEDA generic SSHP.)

2.3 SUBCONTRACTOR RESPONSIBILITIES

(No site-specific changes required to this paragraph. Refer to SEDA generic SSHP.)

2.4 CEHNC PROJECT PERSONNEL

The following CEHNC personnel have been assigned to the safety and health coordination and administration of this project. These personnel shall be contacted whenever changes must be made to the SSHP or WP.

<u>CEHNC Personnel</u>	<u>Responsibility</u>	<u>Phone Number</u>
Fred Wissel	Project Manager	(256) 895-1443
Kevin Healy	Technical Engineer	(256) 895-1627
Kellie Williams	Industrial Hygienist	(256) 895-1584
TBD	On-site Safety Specialist	(256) 895-xxxx

(This space intentionally left blank)

FIGURE 2-1. GENERAL SAFETY AND HEALTH ORGANIZATION

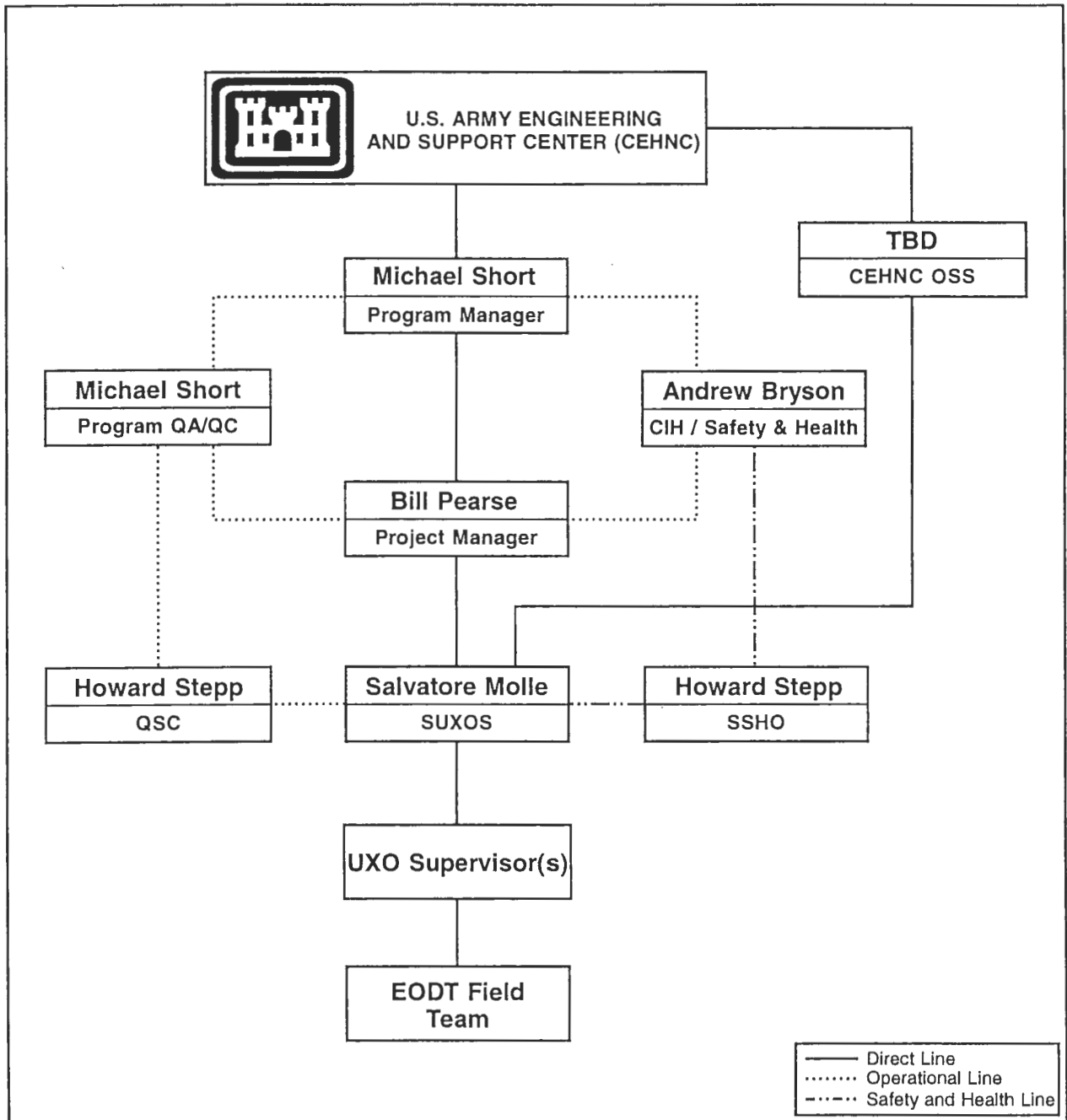

3.0 SITE DESCRIPTION AND CHARACTERIZATION

3.1 SEDA LOCATION AND DESCRIPTION

(No site-specific changes required to this paragraph. Refer to SEDA generic SSHP.)

3.2 DESCRIPTION OF THE OE REMOVAL ACTION SITE

3.2.1 Site Description

Open burning/open detonation (OB/OD) operations have been conducted at SEDA for more than 40 years at the 90 acre Munitions Destruction Area (MDA). The OE RA being conducted during this project will be at the OBG which occupies an area of approximately 30 acres within the southern portion of the MDA. Figure 2 in Appendix C of the WP shows the relative position of the OBG within the SEDA, and Figure 3 shows a closer view of the OBG facility. The OBG is situated on gently sloping terrain and is partially vegetated with grasses and brush. Originally, open burning was conducted directly upon the clay soil surface. However, due to the seasonally wet nature of the local soils, the individual burn pads were subsequently built up with shale and other fill material to provide a drier environment on which to perform the munitions and explosives burning. OE burning and detonation has been performed at nine burning pads labeled A through H and J. Each of these burn pads is surrounded on three sides by an earthen berm created by the bulldozing of surrounding soils and fill material. According to a 1980 Installation Assessment Report, the burn pads were in use from the early 1960's until 1987, when the destruction of munitions was moved to an open air steel enclosure located immediately west of burning Pad D. According to previous investigations, Pads A and J were only used for the burning of trash and rubbish, while pads B through H were used for projectiles, explosives and propellants. Along with the burn pads and berms, the low-lying hill located in the southern portion of the OBG will also be remediated during this project. The formation of the low-lying hill is believed to be time-equivalent to the berms around the burn pads.

3.2.2 Previous Site Investigations

The USACE document entitled Proposed Remedial Action Plan (PRAP) for the Open Burning Grounds (OB) at Seneca Army Depot Activity, includes reference to 22 previous site investigations and studies related to the characterization of the OBG. The referenced studies were conducted on the OBG between 1980 and 1996 and have produced a substantial volume of data related to archival data, soil sampling, monitoring well installations, and groundwater sampling at the OBG. Inclusion of this volume of data is beyond the scope of this WP, however, an examination of the Proposed Remedial Action Plan and the 1994 Final Remedial Investigation Report, indicates that environmentally significant levels of organic and heavy metal contaminants have been detected in the soils of the OBG, with the primary contamination being lead in the soils. Further discussion of the contaminants of concern is presented in paragraphs 3.5.3 and 4.2.2 of this SSHP.



3.3 ON-SITE TASKS TO BE PERFORMED

3.3.1 Introduction

According to both DID OT-005 and ER 385-1-92, a discussion of the tasks to be performed and the hazards associated with each task are to be presented in this Section. However, these documents also require a detailed discussion of the tasks hazards in a separate section related to hazard assessment and risk analysis. To avoid duplication of effort, a general listing of the OE operations is presented below, with a full description of each site-specific task, along with the task-specific hazards, being presented in Section 4.0 of this site-specific SSHP Addendum.

3.3.2 General On-site Tasks That May Be Performed

EODT personnel will be involved in a variety of on-site tasks involving the potential for exposure to various OE, biological, physical and toxic chemical hazards. Brief generic descriptions of the site and task hazards that may be encountered at SEDA are presented in paragraph 3.5 of this section, while the actual on-site hazards will be discussed in each site-specific SSHP Addendum. A general listing of the operations that may be performed is presented below, while the actual tasks needed to meet the SOW for a given site will be presented in the site-specific SSHP Addendum.

- Mobilize personnel and equipment and set-up operational areas.
- Complete the surface OE removal initiated during a previous mobilization to the site.
- Excavate, screen and stockpile soils and debris from the berms, pads, low-lying hill and other site areas according to the levels of lead contamination.
- Sort and segregate the oversize material.
- Conduct location surveying and mapping (LS&M) to re-establish the boundaries/grids.
- Conduct geophysical surveying and mapping (GS&M) of the site.
- Reacquire the anomalies and conduct a subsurface OE clearance of the entire 30-acre site.
- Close out the project site and demobilize equipment and personnel.

3.4 CONTAMINATION CHARACTERIZATION

3.4.1 Chemical Warfare Materials

(No site-specific changes required to this paragraph. Refer to SEDA generic SSHP.)

3.4.2 OE Contamination

Historical records indicate that a large variety of OE were burned and/or detonated at the SEDA OBG. While the post-burn/detonation inspections conducted as part of the OB/OD process will have helped reduce the OE hazards, it is believed that there is still a potential for encountering significant amounts of OE at the site. As a part of the September 1994 Remedial Investigation (RI), an OE contractor conducted surveys and anomaly investigations to clear work areas and access lanes where soil was sampled and monitoring wells were installed. During the OE clearance operations, the OE contractor personnel located and identified various sizes and types of OE with both hazardous and

explosive characteristics. According to the 1994 RI report, and documentation provided to EODT by the CEHNC, the following OE may be encountered at the OBG: primers; detonators; proximity, point detonating, mechanical, mine and time delay fuzes for rockets, mines, projectiles, mortars and bombs; bulk explosives; shape charges; hand and rifle grenades; small arms up to .50 caliber; 20mm, 35mm, 37mm, 40mm, 75mm, 76mm, 90mm, and 105mm projectiles; various bombs, including fragmentation/cluster bombs; and a large variety of mortars and rockets.

3.4.3 Hazardous Substances and Materials

As defined by the Federal EPA, hazardous substances are those products and materials that can threaten human health and/or environmental well-being if released into the environment. Past site sampling and analysis indicates that surface and subsurface soil in various locations of the OBG are contaminated with hazardous substances resulting from past OB/OD operations. As identified in the SEDA Record of Decision (ROD), the contaminants of concern for the OBG are those that exceed the New York State Department of Environmental Conservation guidelines presented in the Technical Administrative Guidance Memorandum (TAGM). According to the ROD, the OBG soil analytes that pose a potential environmental threat are: polycyclic aromatic hydrocarbons (PAH's) benzo(a) anthracene [B(a)A], benzo(a)pyrene [B(a)P] and dibenz(a,h)anthracene [DB(a,h)A]; and the metals barium, copper, lead and zinc. The limits presented in the TAGM are designed to protect potential flora, fauna and human receptors from adverse health effects caused by the accumulation of contaminants from repeated, long term environmental exposures. These limits, however, should not be applied to the assessment of occupational workers experiencing short-term exposures due to soil disturbing activities. Information related to the human hazards associated with short-term, acute exposure to the above listed substances is presented in Table 3-1. An assessment of the potential for personnel receiving an occupational exposure to these substances as a result of site operations is presented in para 4.2.2 of this SSHP.

As a function of site operations, the potential exists for some site personnel to be exposed to potentially hazardous levels of dusts, and personnel may be required to use products containing hazardous materials. The hazardous materials that may be used to support site operations include: gasoline, diesel fuel, two stroke engine oil, and spray paints. It is anticipated that personnel exposure to the hazardous materials will be minimal due to the limited quantities that will be used at any one time. In addition, EODT will provide affected personnel with hazard communication training, as required by paras 6.3 and 6.10 of this SSHP, and will use the work practices outlined in Section 13.0 of this SSHP to further reduce or eliminate the potential for personnel exposure to high dust levels or hazardous materials. To minimize the potential for personnel receiving an excessive exposure to respirable and non-respirable dusts, EODT will employ dust suppression techniques.

TABLE 3-1: SUMMARY OF EXPOSURE STANDARDS AND PROPERTIES FOR ON-SITE CHEMICAL HAZARDS

Hazardous Substance	Exposure Limits	Physical Description	Routes of Exposure	Symptoms of Exposure	Target Organs	Media Where Found	Max. Level Detected
Total Dust	PEL 10 mg/m ³ IDLH NE	Visible dust in the Breathing Zone (BZ).	Inhalation Ingestion	Acute exposures to high concentration may cause irritation of upper respiratory tract, coughing and sneezing.	Lungs, Upper Respiratory Tract.	Soil	NA
Respirable Dust	PEL 5 mg/m ³ IDLH NE	Finely divided particles too small to detect with the human eye.	Inhalation Ingestion	Exposure to high concentrations may result in fibroid scarring of lung tissue.	Upper Respiratory Tract, Lungs	Soil	NA
Barium (Ba) (soluble)	PEL 0.5 mg/m ³ IDLH 1100 mg/m ³	Metal: Usually found as barium nitrate or barium chloride which are white, odorless solids	Inhalation Ingestion Contact	Irritates skin, eyes, nose and throat; muscle spasms; GI disturbances; dermatitis.	Respiratory System, Heart, CNS, Skin, Eyes	Soil Sediment Surface Water	34,400 mg/kg 1,780 mg/kg 523 ug/L
Copper (Cu)	PEL 1.0 mg/m ³ IDLH NE	Metal: none.	Inhalation Ingestion Contact	Irritation of the nasal mucous membranes and pharynx; eye irritation; metallic taste; dermatitis.	Respiratory System, Liver, Kidneys, Skin, Eyes.	Soil Sediment Surface Water	38,100 mg/kg 3,790 mg/kg 60 ug./L
Lead (Pb)	PEL 0.05 mg/m ³ IDLH 700 mg/m ³	Metal: Heavy ductile, soft gray solid.	Inhalation Ingestion Contact	Weakness; facial pallor; loss of weight; anemia; anorexia; constipation; abdominal pain; hypertension.	GI Tract, Central Nervous System, Kidneys, Blood, Gingival Tissue.	Soil Sediment Surface Water	56,700 mg/kg 7,400 mg/kg 74 ug/L
Zinc (Zn)	PEL 5 mg/m ³ ST 10 mg/m ³	Usually found as zinc oxide which is a fine, white, odorless particulate.	Inhalation	Sweet, metallic taste; dry throat; cough, chills with fever-like symptoms; reduced pulmonary function; nausea; vomiting; fatigue.	Respiratory System.	Soil Sediment Surface Water	127,000 mg/kg 1,200 mg/kg NE
PAH's [B(a)P, B(a)A, and DB(a,h)A]	Benzene soluble fraction PEL 0.2 mg/m ³ Suspect Human Carcinogen	Slightly brown in color in pure form, dark in color in mixture	Inhalation Ingestion Contact Absorption	May cause irritation of the skin, eyes and mucous membranes	Skin, Eyes, Respiratory System	Soil Sediment Ground Water	3,700 ug/kg 500 ug/kg NE

NE - None Established
IDLH - Immediate Danger of Life and Health
C - Ceiling Limit

PEL - Permissible Exposure Limit
NA - Not Applicable
ST - Short Term Exposure Limit

4.0 HAZARD ASSESSMENT AND RISK ANALYSIS

4.1 INTRODUCTION

A preliminary evaluation of the on-site tasks to be conducted at the SEDA OBG has been performed. This preliminary evaluation has been conducted using: available site characterization data; chemical and task specific hazard information; and the professional knowledge and experience of EODT's highly qualified staff. The chemical, physical and biological hazards anticipated for this site, as well as the risks of exposure, are discussed in this Section, and are summarized in the Certification of Task Hazard Assessment (CTHA) forms found in Attachment 2 of this SSHP. The control methods and procedures, to include Safe Work Practices (SWP), are discussed in Section 13.0 of this SSHP.

4.2 TASK HAZARD ASSESSMENT AND EXPOSURE RISK ANALYSIS

4.2.1 Introduction and General Requirements

All known, or potential, chemical, physical, biological and safety hazards that may pose a threat to the well-being of site personnel have, to the extent possible, been identified, and the risk of exposure to each assessed. Emphasis has been placed on identifying situations and tasks that have known, or may create, serious safety and health affects or Immediately Dangerous to Life or Health (IDLH) conditions. Due to the potential for exposure to OE and other chemical, physical and biological hazards, the overall hazard level for this project is high and the risk of exposure to OE, safety, physical and biological hazards is also high.

Hazard assessments for SEDA have been made using the best available site data. However, site personnel must understand that hazard evaluation is an ongoing process in which they play a major role, and which will continue for the duration of the project. All site personnel shall be vigilant in identifying hazards in the work place and will bring them to the attention of the SSHA, or the SUXOS. If changes occur in the level or types of hazards present for a currently evaluated task, or if a new task is added to the WP, the SSHA will inform the OSHM of the change and modifications to this SSHP will be made IAW the guidelines in paragraph 1.5 of this generic SSHP.

4.2.2 Hazards and Risks Associated with Potential Exposures to Chemicals

In assessing the risks associated with potential exposures to known on-site chemical contaminants, EODT safety and health personnel examined archival data, current land usages, the physical properties of potential site contaminants, the potential exposure routes, and the operational tasks to be performed to determine what chemical hazards may be encountered during site activities. As a result of this examination, it is believed that none of the environmental contaminants are present in the soil at sufficient quantities that would create a potential for personnel to receive a documented overexposure to the contaminants of environmental concern. This fact will be especially true since EODT is planning on employing real time dust monitoring, SWP's and operational controls to

reduce personnel exposure to contaminant containing dusts. Additional data related to the potential for chemical exposure is presented in para 7.6 of this SSHP. If site activities are modified, or if evidence of additional chemical contamination is found, the potential for chemical exposure will be re-evaluated.

In the event that site personnel find OE, or any other container, which is suspected of containing toxic military chemical agents (i.e., CWM), all site personnel will immediately evacuate the site upwind to a safe location. The procedures outlined in para 3.5.1 will then be followed and the project will continue IAW directions from the CEHNC KO.

4.2.3 Hazards and Risks Associated with OE Hazards

The hazards associated with OE include the possibility of personnel injury or death caused by explosion, fire, fragmentation or over pressurization. These hazards may result if OE are not properly located, identified, handled, transported or disposed. While there is no "safe" procedure for dealing with OE, merely procedures which are considered less dangerous, maximum safety in any OE operation can be achieved through adherence to applicable safety precautions, a planned investigation and remediation approach, and intensive supervision. For all site operations with the potential for exposure to OE, only those personnel absolutely essential to the operation shall be allowed in the restricted area/exclusion zone. Site-specific OE hazards that may be encountered at a given site will be presented in the site-specific SSHP Addendum, and the generic safety and health procedures which will be used for reducing the potential for exposure to OE hazards are discussed in Section 13.0 of this SSHP.

4.2.4 Physical Hazards

Due to the nature of the anticipated site operations at SEDA, the potential and risk for exposure to physical hazards will be high for this project. The physical hazards which may be encountered during site operations include:

- Heat stress and severe weather;
- Flammable/explosive materials used for fueling heavy equipment and power tools;
- Material lifting hazards such as pulled muscles, pinched/crushed fingers and toes;
- Cut/laceration of hands and legs resulting from contact with sharp surfaces/objects;
- Hand and power tool hazards, including cuts/lacerations, noise and flying objects;
- Slip, trip and fall hazards from exposed tree/brush stumps, terrain, and vegetation growth;
- Inclement weather such as heavy rain and thunder/lightning storms;
- Sharp objects including OE fragments, nails, broken glass and exposed tree/brush stumps;
- Pinch points associated with screening and conveying operations; and
- Screening equipment or EMM hazards including noise, pinch point and crush hazards.



Site personnel will be instructed to remain alert to the presence of potential physical hazards and to immediately report the observance of any uncontrolled or unanticipated physical hazards to the SUXOS and the SSHO. The EODT SSHO shall be responsible for thoroughly evaluating each day's field operations with respect to potential physical hazards. Any suspect or known physical hazards, and the specific procedures to be used to control them, shall be reviewed during the daily tailgate safety briefing. General procedures for reducing or eliminating the physical hazards are discussed in Section 13.0 of this SSHP.

4.2.5 Biological Hazards

During portions of the year when the weather is warm, there is a significant probability that site personnel could encounter biological hazards if they are working in vegetated areas. The biological hazards anticipated for this project include: stinging insects like bees, wasps and hornets; poisonous plants, such as poison ivy, oak and sumac; ticks; mosquitoes; spiders; and poisonous snakes. While encountering hazardous insects and animals during the winter months will be remote, site personnel will remain alert to the presence of hazardous plants since toxic skin reactions are possible from contact with the barren plant stems and branches. Employee awareness and the SWP's outlined in Section 13.0 will be used to reduce, or eliminate, the risks associated with these hazards.

4.3 TASK DESCRIPTIONS AND HAZARDS

4.3.1 Task Descriptions

To accomplish the SOW for the OBG, EODT personnel shall perform the general tasks outlined in para 3.3 of this SSHP. To complete those general tasks, EODT personnel will be required to perform several sub-tasks within some of the tasks described previously. A full listing of the tasks and sub-tasks is provided below.

1. Mobilize personnel and equipment and set-up operational areas.
2. Complete the surface OE removal initiated during a previous mobilization to the site. This surface clearance will be magnetometer assisted, and will include anomaly investigation, removal of scrap and ordnance-related scrap (ORS), and disposal of OE.
3. Excavate, screen and stockpile soils and debris from the berms, pads, low-lying hill and other site areas according to the levels of lead contamination as specified below;
 - Remove and screen all Case 1 soils containing greater than 800 milligrams lead per kilogram (mg/kg) soil, as directed by the CEHNC.
 - Remove and screen all Case 2 soils containing less 800 mg/kg but greater than 500 mg/kg, as directed by the CEHNC;
 - Remove and screen all Case 3 soils containing less than 500 mg/kg lead, as directed by the CEHNC; and
 - Remove and screen the top one foot of soil from the remaining areas of the OBG.

4. Sort and segregate the oversize material, to include the location, removal and disposal of hazardous OE.
5. Conduct LS&M of the site to re-establish the boundaries and lay in geophysical survey grids.
6. Conduct GS&M of the site to locate subsurface anomalies.
7. Reacquire the anomalies and conduct a subsurface OE clearance of the entire 30-acre site. This task will involve the relocation of the anomalies, hand digging, investigation and identification of the anomalies; removal of metallic scrap and ORS, and disposal of the OE.
8. Close out the project site and demobilize equipment and personnel.

To ensure that site personnel are fully informed of the nature of the tasks to be performed and the hazards associated with each task, a description of the required tasks/sub-tasks is presented in the following paragraphs. In addition to these descriptions, CTHA forms are presented in Attachment 2 of this Addendum each task, or group of similar tasks. To conduct each specified task, EODT personnel will use the operational procedures outlined in the WP to determine the individual steps to be conducted for each specified task. For the hazards listed for each task, site personnel will utilize the procedures and SWPs outlined in Section 13.0 of this SSHP to control or eliminate the hazards. Site personnel will also comply with the requirements of any relevant SOPs found in Appendix G of the WP.

4.3.2 Mobilize and Set-up Site Operational Areas

EODT personnel will mobilize the equipment and personnel needed to complete the SOW, and will establish operational areas. As part of this task, EODT personnel will establish an office and storage area at the OBG office area located at the main entrance to the MDA. EODT personnel will also establish the support, contamination reduction and exclusion zones required by this site-specific SSHP. The task hazards associated with this task include:

- Inclement weather and heat stress;
- Use of flammable/combustible materials (i.e., fuels);
- Hand tools and power tools;
- Physical exertion; and
- Slips, trips and falls.

4.3.3 Complete the Visual Sweep

EODT personnel will perform a magnetometer assisted visual sweep of the remaining grids in the 30-acre site. This will be conducted to locate any obvious surface OE hazards. The visual sweep procedures are outlined in Chapter 2 of the WP. The task hazards that may be encountered during the surface removal include:

- Surface OE;
- Biological hazards;

- Sharp objects;
- Inclement weather and heat stress;
- Hand tools and power tools;
- Use of flammable/combustible materials (i.e., fuels);
- Excessive noise levels;
- Flying objects and debris;
- Physical exertion; and
- Slips, trips and falls.

4.3.4 Excavate and Screen Soil

The pad berms and the low-lying hill will be excavated and screened to remove all OE and scrap. The sifted soils will then be transported outside the MDA and stockpiled at a site designated by the CEHNC as part of a follow-on hazardous and toxic waste (HTW) remediation project. The principle purpose of the HTW remediation is to remove lead and other heavy metal contamination from the soil. The excavated soils will be removed in one foot lifts and a UXO-qualified safety observer will be stationed at least 19.4 feet from the excavation behind a three inch thick plexiglass shield (as specified by Dr. Crull, Structures Branch, Engineering Directorate, CEHNC). The safety observer will view the operation and notify the excavator operator if any large OE items or other hazards are observed. To protect the excavator operator, a three inch thick plexiglass shield will be attached to the front window of the excavator. The excavator will remove the soil and deposit into the soil screen that will remove all oversize material greater than 20mm. The oversize material will be stockpiled and sorted at a later date. The screened soil will be conveyed from the screen and, if possible, transferred to a dump truck that will transport the screened soil to the stockpile area located outside the MDA. During the screening operation, a safety observer will be stationed on a scissor lift positioned at least 19.4 feet from the screen and elevated so that the observer will be able to see any potential OE in the oversize materials. The observer will be stationed on the lift behind a 3 inch plexiglass shield constructed according to the specifications listed in EODT SOP 120B located in Appendix G of Addendum 1 to the WP. Observation of OE in either the excavation or the screen will require a halt in all excavation and screening operations, with the item being inspected, identified and removed or disposed of by EODT UXO personnel. Procedures for the OE investigation and removal are outlined in Chapter 2 of the WP.

Excavation and screening of soil will be conducted in stages according to the degree of lead contamination and the depth of the excavation. All Case 1, then Case 2, and then Case 3 soils will be excavated from the berms, pads and other areas as specified by the CEHNC. Each category of soil will be screened as it is excavated, with each area excavated in one foot lifts. All screened soils and oversize material will be separated according to the degree of lead contamination. All excavations in each area of each contamination area will be performed in multiple lifts: the first lift

will be to a depth of one foot, with each lift thereafter excavated in one foot lifts until the bottom limit of the lead contaminated soils has been reached. Records of what OE occurred, and at what depth, will be kept for later use in characterizing the subsurface contamination.

After all of the lead contamination has been removed and the berms, pads and low lying hill have been excavated and screened, the 30-acre site, minus the existing berms and the low-lying hill, will be excavated to a depth of 12 inches. All soils removed will be screened and stockpiled outside the MDA. This removal of the top 12 inches is designed to remove the layer of interference that was evident from previously completed geophysical testing and OE removals conducted during a previous mobilization to the site. The hazards that are expected during the soil excavation and screening include:

- Sub-surface OE;
- EMM;
- Hand tools;
- Use of flammable/combustible materials (i.e., fuels);
- Sharp objects, including OE fragments;
- Inclement weather and heat stress;
- Material lifting;
- Excessive noise;
- Dust exposure;
- Physical exertion; and
- Slips, trips and falls.

4.3.5 Sort and Segregate Oversize Material

Oversize material accumulated at the screen shall be stockpiled for future inspection and segregation according to the procedures outlined in the WP. Oversize material shall be sorted to remove any OE through the use of a hopper fed conveyor system that will be manned by EODT UXO personnel. EODT personnel will use a small loader to the feeder hopper, which will feed the material onto a slow moving conveyor belt. As the material proceeds along the conveyor, EODT personnel shall inspect the material and remove any OE-related items or scrap metal. These items shall then be inspected to determine if they are OE or ORS. Suspect inert OE will be stored and explosively vented as required by the WP. Non-OE related oversize shall be removed and stockpiled according to the requirements of the WP. The hazards associated with the sorting of oversize material include:

- OE;
- EMM;
- Use of flammable/combustible materials (i.e., fuels);
- Sharp objects, including OE fragments;
- Inclement weather and cold stress;

- Material lifting;
- Exposure to dust;
- Excessive noise;
- Physical exertion; and
- Slips, trips and falls.

4.3.6 Conduct Location Surveying and Mapping

LS&M will be conducted after all soil removal has been completed to reacquire the grids prior to the performance of a geophysical survey. Survey personnel will be escorted by an EODT UXO Specialist (UXOSP) and will utilize surveying equipment and procedures to stake the four corners of each grid to be investigated. A magnetometer check will be performed at all points where survey stakes, posts, markers, or monuments are to be installed. If a subsurface anomaly is located during the magnetometer sweeps, the UXOSP will report the encounter and mark the anomaly with a pin flag. The task hazards that may be encountered during LS&M include:

- Sub-surface OE;
- Inclement weather and heat stress;
- Hand tools;
- Physical exertion; and
- Slips, trips and falls.

4.3.7 Conduct a Geophysical Survey

Following the relocation of the grids, EODT will conduct GS&M within the OBG site. This survey will be conducted using an EM-61 and/or the White's Spectrum XLT. The resulting geophysical survey maps will allow for the location of subsurface anomalies that will then be relocated and excavated for identification. The task hazards that may be encountered during GS&M include:

- Inclement weather and heat stress;
- Hand tools;
- Physical exertion; and
- Slips, trips and falls.

4.3.8 Investigate Subsurface Anomalies

Using a magnetometer or the Spectrum XLT, EODT personnel will reacquire the subsurface anomalies located during the geophysical mapping. All anomalies will be excavated by hand to a depth of two feet, or as allowed by the absence of bedrock. EODT personnel will excavate the suspect anomalies to identify the anomalies and confirm the presence/absence of OE. Those anomalies lying greater than two feet below the surface will be chased and removed as well, as allowed by the absence of bedrock. Investigations to depths greater than four feet must be approved by the CEHNC OSS and the sloping or shoring requirements outlined in Section 13 of the SSHP will

be used. For the investigation and remediation of an anomaly, EODT personnel will follow the procedures outlined in Chapter 2 of the WP and paragraph 13.13.2 of this SSHP.

Hazardous OE will be disposed of IAW the requirements outlined in Chapter 2 of the WP, and the EODT Demolition and Disposal Range Standard Operating Procedure (SOP) included in Appendix G of the WP. Blow-in-place (BIP) operations will be conducted in all cases where an item is identified as either being fuzed or unsafe to move. For those items that are positively identified as being safe to move, EODT personnel may consolidate the items to reduce the number of demolition shots that must be made. The task hazards that may be encountered during the subsurface OE clearance include the following:

- Sub-surface OE;
- Biological hazards;
- Hand tools;
- Sharp objects, including OE fragments;
- Inclement weather and heat stress;
- Material lifting;
- Handling, transporting, rigging and using demolition explosives;
- Excessive noise;
- Physical exertion; and
- Slips, trips and falls.

4.3.9 Turn-in Ordnance Related Scrap

ORS located and identified during the OE RA process will be collected, and disposed of IAW the requirements of the SOW. All scrap shall be stored in an area approved by the CEHNC OSS. As the scrap is collected, a four step process will be conducted which requires that the ORS be inspected by: 1) the UXOSP who found the item; 2) an additional UXOSP; 3) the SSHO; and 4) the SUXOS. This inspection system will ensure that no explosive hazards are present prior to final disposition. Prior to the ORS being transferred from the site, the EODT SUXOS will complete a certification form verifying that the scrap is safe, and free of explosive hazards. Site personnel will wear leather gloves at all times when handling ORS/non-ORS. The task hazards that may be encountered during scrap turn-in include the following:

- OE;
- Sharp objects, cuts and lacerations;
- Inclement weather and heat stress;
- Material lifting;
- Physical exertion; and
- Slips, trips and falls.

4.3.10 Perform Project Quality Control

The EODT QCS shall be responsible for the continued compliance of on-site tasks with relevant QC procedures. The QCS shall enforce the QC procedures outlined in the WP by conducting daily inspections of the site and site operations. The task hazards that may be encountered during QC inspections include the following:

- OE;
- Biological hazards;
- Inclement weather and heat stress;
- Heavy equipment operation;
- Excessive noise;
- Physical exertion; and
- Slips, trips and falls.

4.3.11 Close-out the Site and Demobilize Equipment and Personnel

Once the project has been completed and the on-site portion of the SOW has been accomplished, EODT personnel will arrange for the collection of ORS and non-ORS IAW the requirements of the WP. Additionally, EODT personnel will return all EMM and other equipment, and will secure the site prior to final departure. The hazards associated with this task include:

- EMM;
- Use of flammable/combustible materials (i.e., fuels);
- Hand tools;
- Sharp objects, including OE fragments;
- Inclement weather and heat stress;
- Material lifting;
- Physical exertion; and
- Slips, trips and falls.

4.4 COMMUNICATION OF TASK HAZARD INFORMATION

(No site-specific changes required to this paragraph. Refer to SEDA generic SSHP.)

4.5 EMPLOYEE RIGHT-TO-KNOW HAZARD COMMUNICATION

(No site-specific changes required to this paragraph. Refer to SEDA generic SSHP.)

4.6 CERTIFICATION OF TASK HAZARD ASSESSMENT

(No site-specific changes required to this paragraph. Refer to SEDA generic SSHP.)



5.0 ACCIDENT PREVENTION

(No site-specific changes required for this Section. Refer to the SEDA generic SSHP for data related to this Section.)

(This space intentionally left blank)



6.0 TRAINING PLAN

(No site-specific changes required for this Section. Refer to the SEDA generic SSHP for data related to this Section.)

(This space intentionally left blank)

7.0 PPE PROGRAM

7.1 INTRODUCTION

All personnel performing operations on site shall be required to use the appropriate level of protection, as specified in this section and the CTHA forms presented in the site-specific SSHP Addendum. It is anticipated that site personnel may be required to perform operations in levels of PPE ranging from Level D, to Modified Level D, and Level C, IAW the hazards associated with a given task or operation. All PPE requirements for site operations, activities, or zones will be based on available site characterization and historical data and will represent the initial PPE levels that will be used during the start of specific site operations. Initial levels of PPE may be down-graded based upon the site monitoring results obtained IAW the Site Monitoring Plan presented in Section 9.0 of this SSHP. The PPE levels presented in this Section will be reassessed if any of the following occur:

1. The results obtained from the on-site monitoring are below the action levels specified for the initial/current PPE levels;
2. The results obtained from the on-site monitoring are above the action levels specified for the initial/current PPE levels;
3. Previously unidentified chemicals or conditions are noted;
4. Significant changes in weather conditions occur which impact the use of assigned PPE;
5. A new task is introduced to the SOW or a previously assigned and evaluated task is expanded in scope; and
6. Discovery and confirmation of CWM.

For project tasks assigned after the approval of this SSHP, the EODT OSHM, in conjunction with the SSHO, will assess the task hazards, assign the appropriate PPE level, complete a Certification of Task Hazard Assessment form and forward it to the KO for approval. Upon approval, the new form will be added to this SSHP. Any changes in PPE levels involving the downgrading of PPE levels will be allowed only after review and approval by the EODT OSHM.

7.2 SPECIAL CONSIDERATIONS

(No site-specific changes required to this paragraph. Refer to SEDA generic SSHP.)

7.3 TASK SPECIFIC ASSIGNMENT OF PPE

Table 7-1 presents a listing of the anticipated site tasks and the initial level of PPE that will be worn during the performance of each task. Modifications to Table 7-1 may be required and levels of PPE may be upgraded or downgraded according to the results of on-site air sampling and monitoring. Revisions to this table will only be made upon approval of the EODT OSHM.

7.4 LEVEL D PPE

The following PPE will be worn during general site activities IAW Table 7-1:

1. Work clothes or coveralls (cotton);
2. Leather work gloves;
3. Boots - all leather work boots;
4. Hard hat (as required, see paragraph 7.2);
5. Snake leggings (required when working in wooded/vegetated areas during warm weather conditions where snakes may be present on site);
6. Rubber over boots;
7. Safety glasses (as required for eye impact and UV protection); and
8. One two-way radio per team.

TABLE 7-1: TASK SPECIFIC ASSIGNMENT OF PPE LEVELS

Task to be performed	Level of PPE
Mobilization and site set-up / Demobilization and site closure	D
Magnetometer assisted surface clearance	D
Location surveying and mapping	D
Magnetometer surveys	D
Investigation of anomalies - high lead areas (i.e., Case 1 areas only)	Modified C
Investigation of anomalies (all other areas)	D
OE disposal operations	D
EMM operation - high lead areas (i.e., Case 1 areas only)	Level C
EMM operation (areas of low level lead contamination)	D
Soil screening operations - high lead areas (i.e., Case 1 areas only)	Level C
Soil screening operations (all other areas)	D
Sorting of oversize materials - high lead areas (i.e., Case 1 areas only)	Modified C
Sorting of oversize materials (all other areas)	D
Perform QC and safety inspections/observe site operations	Equal to operation
Handling scrap metal and ORS	D
Refueling of powered and heavy equipment	D (w/ chemical gloves)

7.5 MODIFIED LEVEL D PPE

The following PPE will be worn for those tasks requiring Modified Level D PPE:

1. Same as Level "D", but with the following additions;
2. Hard hat with face shield (wire or nylon mesh);
3. Leather anti-vibration work gloves;
4. Kevlar chaps (for use with chain saw);
5. Rubber over boots;
6. Toe guards or steel-toed boots; and
7. Ear plugs and muffs.

7.6 LEVEL C PPE

7.6.1 Standard Level C PPE

Due to the presence of lead identified in the soil during past site characterization sampling, standard Level C PPE has been assigned only as a precautionary measure for those dust producing tasks conducted in the high lead areas. As stated previously, EODT anticipates that Level C PPE will not actually be needed for the site operations due to the following:

1. The maximum concentration of lead in the soil presented in Section 3.0 represents the worst case scenario;
2. While the maximum concentration previously detected is 56,700 mg/kg, the average concentration of lead in the soil, as presented in the ROD, is only 1,888 mg/kg, which indicates that most of the soil samples were substantially below the maximum concentration, and therefore the potential for an over exposure is significantly less than that associated with the maximum level.
3. EODT will conduct real-time monitoring of dust concentrations in the breathing zone (BZ) to ensure that dust levels are maintained below an action level that would produce a potential for over exposure (see Table 9-1).
4. Dust suppression techniques will be used as needed to reduce dust levels in the workers breathing zones.

Level C PPE will be used until personal BZ sampling can document that there is no potential for personnel receiving an exposure to lead above the action level presented in Section 9.0. Level C PPE will be discontinued when sampling results are obtained indicating that the lead exposure is below the action level. During the initial conduct of potential dust producing activities in the areas of high lead contamination, Level D PPE will be worn along with the following PPE for those tasks requiring Level C:

1. Tyvek suit with attached hood and boots;
2. Nitrile outer gloves;

3. Rubber over boots; and
4. Fullface respiratory protection with HEPA filters.

7.6.2 Modified Level C PPE

Modified C PPE will be worn for those activities where personnel will be digging or coming in contact with soils in the high lead contaminated areas. For those tasks requiring Modified Level C, Level D PPE will be worn along with the following PPE:

1. Nitrile outer gloves; and
2. Tyvek coveralls.

7.7 RESPIRATOR ISSUE

The following respiratory requirements have been designed to comply with applicable OSHA and USACE regulations found in 29 CFR 1910.134 and EM 385-1-1 Section 5.E. These requirements also comply with the requirements of the EODT Respiratory Protection Program, and shall not be changed without prior approval from the OSHM.

7.7.1 Respirator Selection

The OSHM has utilized available site archival and characterization data, and information related to the physical and toxic properties of site contaminants, to select the respiratory protective equipment for each task. At no time will respirators or their components be altered or combined in a manner that is not approved. Doing so may void the respirator approval and significantly affect the performance of the respirator.

7.7.2 Selection Criteria

The selection of the proper type of respiratory protection has been and shall continue to be based upon the following:

1. The type of contaminant(s) expected or known to present a potential for exposure;
2. The physical properties, toxicological effects, and anticipated exposure concentrations;
3. The warning properties and initial signs and symptoms of exposure;
4. The nature of the operation where exposure may occur;
5. The location of the work area in relation to the nearest area having respirable air;
6. The period of time for which respiratory protection is needed; and
7. The characteristics and limitations of the respirator.

7.7.3 Task-Specific Respiratory Assignment

A fullface respirator with High Efficiency Particulate Air (HEPA) filters has been selected for those project tasks where an initial determination of the lead exposure levels must be made to ensure that personnel do not receive an unprotected overexposure. Any modifications to the type of respiratory



protection specified by this section will be made in writing, approved by the OSHM and CEHNC CO and amended to this SSHP. Respiratory protection will only be issued to those personnel who have been medically cleared to wear respiratory protection and who have a current fit test for the type of respirator being used.

7.7.4 Respirator Training

Training in the use of respiratory protective equipment shall be conducted by the SSHO prior to the on-site use of respiratory protection. The respiratory training shall be conducted IAW with the provisions outlined in Section 6.0 of this SSHP and shall be documented by the SSHO.

7.8 PPE INSPECTION, MAINTENANCE AND STORAGE

Site personnel using PPE will keep the equipment clean, and in good working condition. EODT shall establish and maintain a PPE storage area where field personnel may store their PPE during non use times. Respirators used on site will be allowed to dry after decontamination in an area that is free of site contaminants and other hazards. All site personnel will be responsible for daily inspections of their PPE to ensure that it is maintained in safe working order. PPE that is worn out or defective will be brought to the attention of the SSHO and replaced as needed.

(This space intentionally left blank.)



8.0 MEDICAL SURVEILLANCE

(No site-specific changes required to this Section, with the exception of the paragraph identified below. Refer to SEDA generic SSHP for all remaining Medical Surveillance requirements.)

8.5.2 Project Specific Testing

Prior to, and upon completion of site operations, those site personnel with a potential for exposure to lead contaminated soils will have a blood test for lead and zinc polyporphorin levels. These tests shall be conducted prior to site personnel participating in dust producing activities and prior to site personnel leaving the project.

(This space intentionally left blank)



9.0 MONITORING PLAN

On-site sampling and monitoring will be conducted during specified site activities to evaluate potential chemical and physical hazards that may be encountered during site activities. The on-site monitoring will assist in determining the effectiveness of control measures, the need for upgrading or downgrading PPE requirements, and the effectiveness of safe work practices. Direct reading, real-time instruments will be used whenever possible, or required, during site operations to detect and qualify the hazards. If a reading is achieved which exceeds the action levels specified in Table 9-1, the EODT SSHO will take the steps outlined in this Section to correct the situation or minimize the exposure.

9.1 MONITORING RESPONSIBILITIES

Sampling and monitoring will be conducted by the EODT SSHO, or other site personnel trained by the SSHO in the proper calibration and operation of monitoring equipment. All monitoring equipment will be provided and operated by EODT. Any readings at or above the action levels, as specified in Table 9-1, will be reported to the OSHM. The sampling and monitoring equipment to be used during operations will include the instruments listed below.

1. Sound level meter - A sound level meter will be used as a screening device to measure sound power being emitted by a source. This instrument helps identify operations where hearing protection and noise dosimetry monitoring may be needed.
2. Noise dosimeter - To be used to calculate the 8-hr time-weighted average (TWA) noise exposure.
3. Real-time dust monitor - This instrument will be used to assess the levels of respirable dust in the worker's BZ, and shall be used for all potential dust producing activities.
4. Direct reading thermometer - The thermometer will be used to assess cold stress IAW Section 10.0 of this SSHP.
5. Personal air sampling pumps - The personal air sampling pumps will be used to collect BZ samples from personnel during dust producing activities performed on soils removed from the high lead contaminated areas.

9.2 MONITORING SCHEDULE

Exposure sampling and monitoring will focus on the potential exposure to chemical and physical hazards generated during high noise activities and dust producing activities conducted for soils from areas of high lead contamination. Table 9-1 identifies the type of monitoring equipment to be used, the frequency at which the monitoring will be conducted, assignment of monitoring responsibility, monitoring method to be employed, action level, and resultant action to be taken.

TABLE 9-1: SITE MONITORING SCHEDULE AND ACTION LEVELS

Hazard to be Monitored	Monitoring Equipment	Monitoring Responsibility	Monitoring Frequency/Location	Action Level	Action to be Taken
Dust	Real-time, direct reading respirable and total dust monitor.	EODT SSHO	Conducted continuously in the BZ and work area of personnel with the greatest potential for exposure during dust producing activities with soils from high lead contaminated areas.	<ol style="list-style-type: none"> 1. Average of <math>0.5 \text{ mg/m}^3</math> in the BZ 2. Average of 0.5 mg/m^3 in the BZ 3. Average of 1.0 mg/m^3 in the BZ 	<ol style="list-style-type: none"> 1. Reduce PPE to Level D if supporting data available from integrated sampling. 2. Increase dust suppression techniques if using Level D PPE. 3. Halt operations, apply dust suppression and upgrade to Level C PPE.
Lead	Integrated sampling pump and collection media	EODT SSHO	Conduct two days of integrated sampling of personnel with the highest exposure potential for during the start of each dust producing task with soils from high lead contamination areas.	<ol style="list-style-type: none"> 1. $> .025 \text{ mg/m}^3$ 8 hr TWA 2. $> .015$ but $< .025 \text{ mg/m}^3$ 8 hr TWA 3. $< .015 \text{ mg/m}^3$ TWA 	<ol style="list-style-type: none"> 1. Remain at Level C and attempt to reduce exposure, continue sampling. 2. Downgrade to Level D but maintain dust suppression and real-time monitoring. 3. Downgrade to Level D
Heat Stress	Digital Oral Thermometer	EODT SSHO	As required by the SSHO, based upon site conditions and the requirements of Para 10.5 of this SSHP.	<ol style="list-style-type: none"> 1. Oral Temperature greater than 99.6°F. 2. Oral Temperature greater than 100.4°F. 	<ol style="list-style-type: none"> 1. Reduce next work cycle to two thirds of last cycle. 2. Halt operations involving impermeable and semi-permeable clothing.
Noise	Sound Level Meter	EODT SSHO	Conducted initially during the operation of potential high noise operations, and periodically thereafter, according to the recommendations of the EODT OSHM, and for each demolition shot.	Sound levels greater than 85 dBA.	Conduct noise dosimetry reading to determine the 8-hour noise TWA. Effected personnel will be issued and use hearing protection devices during the monitoring.
	Noise Dosimeter	EODT SSHO	Whenever noise levels in the hearing zone exceed 85 dBA.	None set, follow directions in Action to be Taken column.	Report dosimeter readings to the EODT OSHM to ensure hearing protection is adequate for the level of noise experienced.



The guidelines presented in Table 9-1 represent the minimum requirements. Monitoring frequency will be escalated or reduced based on the results of previous monitoring and/or other signs of potential exposures (odors, etc.). Monitoring for airborne hazards with the direct reading instruments will be conducted in the BZ, in the work area, and on the perimeter of the exclusion zone whenever possible. Monitoring for high noise will be conducted in the worker's hearing zone.

9.3 NOISE MONITORING

High noise levels associated with vegetation clearing equipment, the EMM and the sifter, will be monitored to determine if hearing protection devices will be required, and to ensure that the level of hearing protection being used is adequate. At the start of potential high noise operations, sound level readings will be taken in the hearing zone of the effected personnel. Noise dosimetry will be conducted for any operation where sound level readings indicate a potential for exposures above 85 dBA. Table 9-1 will be consulted to determine the type, amount and frequency of noise monitoring.

9.4 HEAT STRESS MONITORING

Heat stress monitoring will be conducted IAW the guidelines presented in Section 10.0. This monitoring will be conducted by the SSHO, and will be used to adjust personnel work schedules and rates in the event that temperature extremes are experienced during site operations. The action levels presented in Table 9-1 will be used by the SSHO to determine when, and what type of, adjustment to site operations will be required to minimize the potential for heat or cold stress.

9.5 REAL-TIME MONITORING OF RESPIRABLE DUST LEVELS

Due to the known potential for heavy metals to be present in the soil, monitoring for respirable dust will be conducted in the BZ of the workers involved with potentially high dust level activities during the processing of soils with high lead levels. The action levels for real-time respirable dust levels are specified in Table 9-1. Monitored levels in excess of this action level will require increasing methods of dust control and/or upgrading of PPE, as determined by the OSHM.

9.6 PERSONAL BZ SAMPLING FOR LEAD CONTAINING DUST

To assess 8-hour TWA exposures to lead containing dust, full shift, integrated air sampling will be conducted for soil excavation and screening tasks conducted on the soils from the high lead areas designated by the CEHNC OSS. Due to probable wetness of the soil to be excavated, or through the use of dust suppression techniques, it is anticipated that dust levels can be maintained at low concentrations. However, to ensure compliance with OSHA's Lead standard, 29 CFR 1910.1025, personal breathing zone samples will be collected to determine the potential for lead exposure at the soil excavation and screening operations during the processing of soils with high lead contents. The air samples will be collected IAW approved NIOSH or OSHA sampling techniques using a personal sampling pump calibrated to 2.0 liters per minute, connected to a mixed cellulose ester filter. The



SSHO will begin sampling of site personnel conducting dust producing activities when operations are initiated in the areas identified as high lead contamination areas. After collection of the air samples, the samples will be sent to an American Industrial Hygiene Association accredited lab capable of rapidly reporting the results. The OSHM will be responsible for evaluating the sample results and determining a need for further sampling and/or the down grading of PPE.

9.7 MONITORING EQUIPMENT CALIBRATION AND MAINTENANCE

All sampling and monitoring instrumentation used on site will be calibrated and/or response checked IAW the manufacturer's specifications, before and after use each day. If an instrument fails to calibrate or respond correctly, it will be removed from service until it can be repaired IAW manufacturer's specifications. Instruments used in the EZ during operations related to soils with high lead levels will be cleaned with wet wipes after each day of use to remove any gross amounts of dust or debris.

(This space intentionally left blank.)



10.0 HEAT AND COLD STRESS PREVENTION

(No site-specific changes required for this Section, with the exception of the Cold Stress requirements which have been removed from this site-specific SSHP for the OBG. Refer to the SEDA generic SSHP for data related to Heat Stress.)

(This space intentionally left blank.)



11.0 SITE CONTROL

11.1 CENTER OF OPERATIONS

The EODT field office and storage areas for the SEDA OE RA project will be located at the main office facility located at the entrance to the MDA where the OBG is located. This facility will allow EODT to store project documents, files, materials and supplies in a lockable area that will be secured at the end of each day's operations. Both SEDA and off-facility phone communications will be available at the EODT center of operations.

11.2 PROJECT SITE ACCESS

Since only one road leads into the MDA, and since the area is fenced, project site access will be controlled at the lockable gate located on the main access road near the offices. Once EODT initiates site activities with the potential for generating site hazards, EODT will establish a control point at this location directing visiting personnel to check in at the site office. In addition, the gate will be locked and visitors will be denied access during any on-site demolition operations.

11.3 WORK ZONE ACCESS CONTROL AND SECURITY

For the purpose of this project, a WZ is defined as any location where EODT or subcontractor personnel are conducting any of the site tasks specified in Section 4.0 of this SSHP. Authorized entry into the various WZs will be given to only those personnel required to safely conduct the task at hand, and visitors will be controlled and escorted as described in this Section. Ensuring that a WZ is secure will be the primary duty of the SUXOS and SSHO, but all site personnel will take an active role in ensuring that the site is not accessed by unauthorized personnel. For this project, EODT shall utilize a system of rope, engineering tape, flags or signs to establish the following WZ's according to the requirements presented below:

1. Support Zone (SZ) - Upon arrival at the site, EODT personnel shall establish and maintain a SZ which shall encompass the entire 30-acre site and the locations of the soil stockpile areas. Once on-site operations beyond the mobilization/site set-up task are initiated, access to the support zone will be restricted to only approved EODT, subcontractor and CEHNC personnel. All other personnel entering the site shall be considered visitors and will be treated according to the requirements of this Section. The SZ shall be the location where EODT shall stage site support equipment and facilities. This area will be positioned, if feasible, in a location up wind of the OBG.
2. Contamination Reduction Zone (CRZ) - The CRZ shall be established prior to site personnel entering the site to conduct any on-site tasks. This zone shall contain the Personal Decontamination Station (PDS) that will be used by site personnel to decontaminate PPE prior to its removal.

3. Exclusion Zone (EZ) - This zone shall be established prior to site personnel entering the site to conduct any on-site tasks. Due to the potential for lead contamination, only those personnel who have met the training and medical surveillance requirements of this SSHP shall be allowed to enter the EZ for any reason once on-site operations commence. Personnel exiting the EZ shall do so only through the CRZ PDS and shall be logged in and out of the EZ by the SSHO.

Due to the nature of site activities, various WZ's may be established within the EZ according to the tasks being conducted at a given time at a given place on the site. For example, during on-site excavation and screening of the soils contaminated with high lead levels, EODT shall establish a separate EZ within the main EZ to exclude those personnel without a need to be in the area(s) where exposure lead may occur.

11.4 SITE CONTROL DURING DEMOLITION OPERATIONS

Site access control will be especially critical during demolition operations. OE found within a given grid will be either be BIP or if found unfuzed and safe to move, may be stockpiled and stored in an appropriate storage area for disposal at the end of the day. During demolition operations, the demolition team will post a sufficient number of sentries in strategic locations so as to effectively secure the EZ in a full 360° arc around the demolition location. The size of the EZ will be determined in the field according to the requirements of the WP and the type of ordnance being disposed of. Besides the road block at the entrance, additional road blocks may be placed and manned by EODT personnel if the need arises and after coordination with the CEHNC OSS and the SEDA Duty Officer. During demolition operations, EODT will also utilize bullhorns and sirens to announce verbal and audible warnings prior to initiating the demolition shot.

11.5 EQUIPMENT STORAGE AND SECURITY

During non-working periods, all project equipment used on site, to include hand tools, will be secured in a lockable location. For the storage of explosives, EODT shall use Government provided facilities which will remain locked at all times when explosives are not being issued or received. Two keys will be required to gain access to the magazine, and EODT ordnance accountability and explosives logs will be used to control inventory.

11.6 SITE MAPS

Prior to initiation of site activities, the SSHO and SUXOS will generate a site map, which will detail the following information: site size and shape; restricted areas; designated assembly points; the site access routes; demolition areas; staging areas; location of the CRZ, any other information deemed necessary by the SUXOS or SSHO. The site map will be used by the SSHO during the initial site safety training and the daily tailgate safety briefings to inform site personnel of the locations of the

areas listed above. To prevent excessive cluttering, overlays can be used to portray the necessary information. The site map will be created prior to initiating site activities, and the SSHO will forward a copy to the OSHM for inclusion in the SSHP. This map will also be posted in the office trailers. General maps of the SEDA project site are included in Appendix C of the WP.

11.7 SITE COMMUNICATIONS

Effective on-site and off-site communication is an integral part of site control and will be established prior to initiating site activities. On-site communication will be used to: coordinate site operations; maintain site control; pass along safety information, work/rest periods, etc.; and to alert site personnel to emergency situations. Off-site communication will be available to ensure effective communication with off-site management personnel and emergency response services. All site personnel will be familiar with the different methods of both on-site and off-site communication. The methods for site communication that will be used on this project are:

1. Off-site Communication
 - a. Cellular and hard wire telephones.
2. Communication on site
 - a. Two-way radios with the base station located in the field office;
 - b. Air horns, bullhorns and sirens; and
 - c. Hand signals.

Site personnel will be familiar with the following hand and audible signals:

1. Hand gripping throat: "Breathing problem, can't breathe".
2. Thumbs up: "OK, I'm all right, I understand".
3. Thumbs down: "No, negative".
4. Pointing to ear(s): "Can't hear, don't understand".
5. Waving hand(s) over head: "Need assistance now".
6. Pointing to eyes then pointing to person/object: "Watch person/object closely".
7. Grab buddy's wrist: "Evacuate site now, no questions".
8. One long air horn blast: "Evacuate site to assembly point".
9. Two short air horn blasts: "Condition under control, return to site".

11.8 BUDDY SYSTEM

An important element in controlling personnel exposure to site hazards is the implementation of buddy system procedures. These procedures ensure that no site personnel are allowed to work without another qualified worker present to provide assistance if needed. At all times buddies should be able to:

1. Observe their buddy for signs of exposure to chemical, physical or biological hazards, with special emphasis to symptoms of heat/cold stress;



2. Periodically check the integrity of their buddy's protective clothing;
3. Observe the site area in which they are working for hazards;
4. Remain within verbal or visual contact with their buddy at all times; and
5. Notify the team leader and or field office if emergency assistance is needed.

(This space intentionally left blank)



12.0 PERSONNEL AND EQUIPMENT DECONTAMINATION

12.1 GENERAL HYGIENE

Personal hygiene and sanitation facilities will be established on site IAW 29 CFR 1910.120(n) and EM 385-1-1, Section 2, to ensure that personnel maintain good personal hygiene. These facilities shall include a personal washing area, toilet facilities, and a lunch/break area for all site personnel. In the office area, sanitary facilities are provided as part of the site office complex. However, under field conditions where a project site is not provided with a sanitary sewer system, temporary chemical toilet facilities will be used by EODT to fulfill the sanitary toilet requirement. Each temporary toilet shall be naturally lighted, have ventilation, be lockable from the inside, and shall be serviced weekly. EODT will provide a minimum of two temporary toilets in the SZ.

Hand and face washing facilities will be utilized by all personnel exiting the EZ prior to eating, drinking, tobacco use, or other hand-to-face activities. Due to the remoteness of the SZ, and the lack of immediately available water resources, handi-wipes and rinse water will be provided for on-site hand and face washing. When site personnel are returning to the office area at lunch and prior to leaving the site, the running water facilities in the office area will be used to conduct a final washing. This washing at the office facility will be preceded by hand and face washing at the CRZ/SZ line.

12.2 POTABLE AND NONPOTABLE WATER SUPPLIES

An adequate supply of potable (drinkable) water shall be provided on site at all times, and will be supplied IAW the following provisions:

1. Containers used for potable water shall be capable of being tightly closed, equipped with a tap, maintained in a sanitary manner, and cleaned at least weekly;
2. A container used for distribution of drinking water shall be clearly labeled as to its contents and not used for any other purpose;
3. Where single service cups are provided, separate sanitary containers will be provided for the storage of the unused cups and for the disposal of the used cups; and
4. Water shall not be dipped from the container and use of a common cup shall not be allowed.

Outlets and storage containers for nonpotable water, such as water for fire fighting or decontamination will be conspicuously labeled "Caution - Water unfit for drinking, washing or cooking". At no time will there be a cross connection or open potential between a system furnishing potable water and a system furnishing nonpotable water.

12.3 SITE HOUSE KEEPING

All work areas will be maintained in a clean/neat fashion, free of loose debris and scrap. Any materials/equipment not being used will be removed and stored or disposed of accordingly. All work



areas shall be supplied with a trash receptacle with lid, the contents of which shall be emptied daily into a central storage container that will be tightly closed each night prior to departing the site.

12.4 PERSONNEL DECONTAMINATION

To minimize the potential for site personnel carrying lead contamination into clean areas, a personnel decontamination station (PDS) shall be established in the CRZ to facilitate decontamination, and protective clothing removal. The PDS shall be established prior to, and utilized during, any site activities involving the potential for personnel exposure to soil in the lead contamination areas. To the greatest extent feasible, the PDS shall be established up-wind from the EZ and shall be geographically located to minimize exposure of the unprotected personnel and equipment in the SZ to contaminated personnel/equipment. During the set up of the PDS, signs shall be set up at each station to remind personnel of the proper activity to be conducted at the particular station.

Since it will be possible for site personnel to be conducting different operations in different areas of the EZ, and for personnel in different areas of the site to be wearing differing levels of PPE, one PDS will be established which will facilitate the decontamination of all levels of PPE anticipated for this project. Figure 12-1 graphically depicts the PDS that will be established and indicates the differing steps that will be used for the decontamination of the various PPE ensembles. Only those personnel using Level C PPE will utilize all of the stations and when Level C has been discontinued, the stations specific to Level C will be closed.

12.4.1 Emergency PDS

An Emergency PDS (EPDS) will be set-up immediately adjacent to the PDS to facilitate the decontamination of incapacitated personnel. The EPDS will make available all the necessary resources for rendering first aid and decontamination. The EPDS will allow for the rapid and safe decontamination, PPE removal and transportation of an injured worker across the hot line. The EPDS will be set-up as outlined in Figure 12-1 and will, include the following stations and supplies:

<u>Station A (in the EZ)</u> HZ drop cloth with two five-gallon sprayers (one with a soap solution and a second with clean water), blunt-nosed scissors and first aid supplies.	<u>Station C - Opposite Station A (in the CRZ)</u> Drop cloth with first aid kit, eye wash kit, burn blanket, bloodborne pathogen universal controls kit, and fire extinguisher.
<u>Station B (in the EZ)</u> Porous stretcher for EZ side of the Hot Line.	<u>Station D - Opposite Station B (in the CRZ)</u> Stretcher for the PDS side of the Hot Line.

Figure 12-1: PDS for Level C PPE

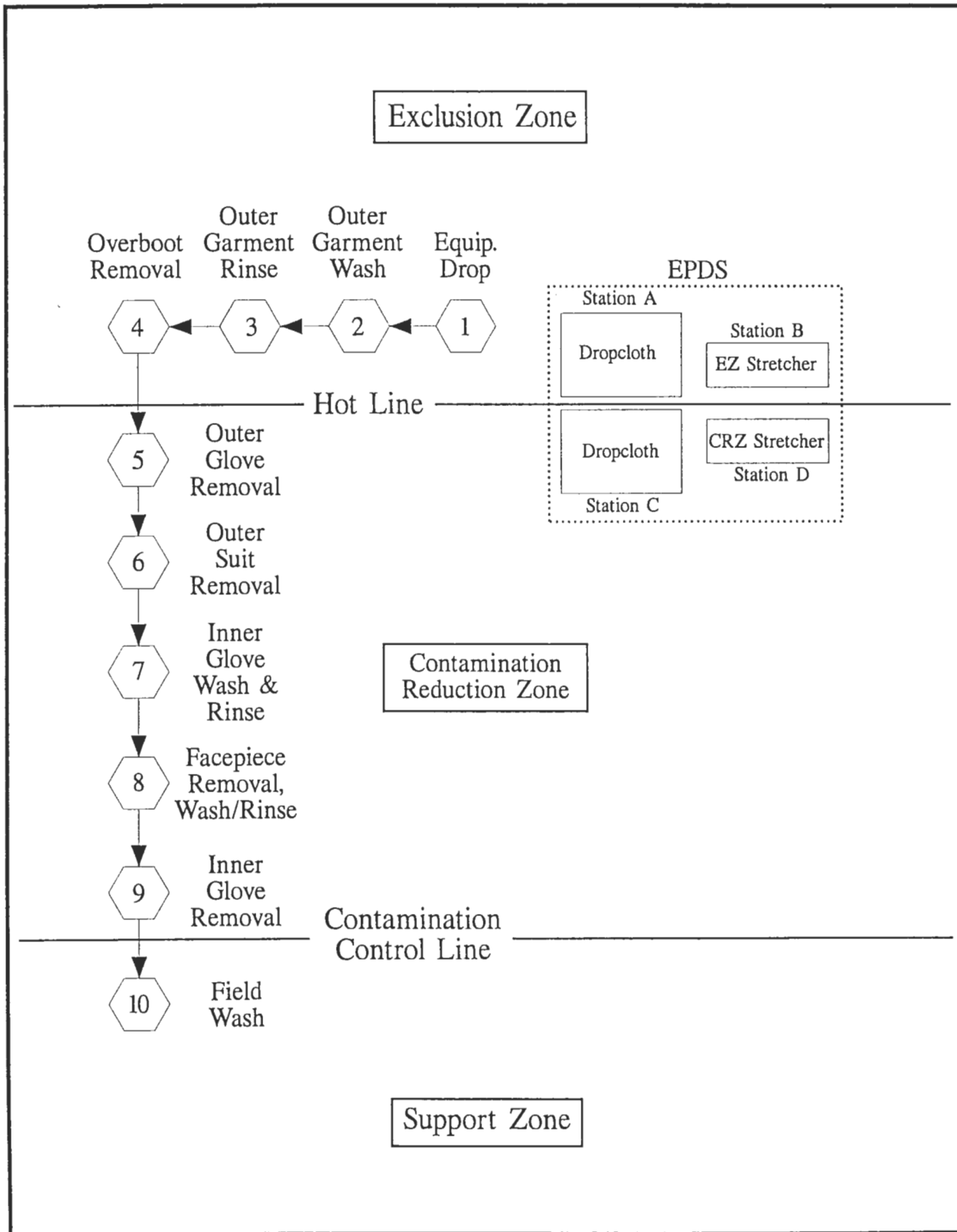



12.4.2 Level C PPE Decontamination

To perform effective contamination control, contamination must not be carried on personnel, clothing or equipment into the clean SZ. To ensure proper and effective decontamination, site personnel exiting lead contamination areas where Level C is used will decontaminate using the stations listed in this paragraph and illustrated in Figure 12-1.

Station 1: Equipment Drop

Enter PDS at Station 1 and deposit all reusable equipment on the drop cloth.

Station 2: Outer Garment Decontamination (Chemical Suit, Gloves, and Boots)

Using the sprayer with soap solution, and starting at the head and working down, spray the entire surface of outer garments and scrub the bottoms of the over boots.

Station 3: Outer Garments Rinse

Using the sprayer with clean water and starting at the head and working down, remove all soap residue from the outer garment.

Station 4: Boot Removal (Boot Rack)

Remove boots and place in plastic-lined container. Do not place unbooted feet back across the Hot Line. A chair or bench and boot jack will be provided at this station to assist boot removal.

Station 5: Outer Glove Removal

Remove outer gloves and place in plastic-lined container. Personnel should exercise extreme caution, and make every effort not to touch the inner gloves with the outside of the outer gloves during their removal.

Station 6: Outer Suit Removal

Remove outer suit and place in plastic lined container. Buddy will assist in removal of the suit in an inside-out fashion, using caution to touch the outer part of the suit with the inner gloves as little as possible.

Station 7: Inner Glove Wash and Rinse

Wash inner gloves in soap solution and rinse in clean water.

Station 8: Respirator Removal and Wash/Rinse

Remove respirator and place in plastic bag.



Station 9: Inner Glove Removal

Remove inner gloves and place into plastic-lined waste container, using caution not to touch the outside of the inner gloves with the hands.

Station 10: Conduct Field Wash

Using soap and water, or handi-wipes, wash hands, face and neck immediately upon exiting CRZ.

12.4.3 Modified Level C PPE Decontamination

For those personnel working in Modified Level C PPE, decontamination will involve going through Stations 1 through 7, 9 and 10. These decontamination steps will allow for the effective decontamination of the tyvek coveralls and outer gloves and boots.

12.4.4 Level D and Modified Level D PPE Decontamination

For those personnel working in Level D and Modified Level D PPE, decontamination will involve Stations 1 through 4 and 10, which will allow for the washing, rinsing and removal of the outer over boots.

12.5 EQUIPMENT DECONTAMINATION

Tools and equipment used on site will be kept free of accumulations of soil and other debris and will be washed prior to removal from the EZ. Equipment used in the field, to include PPE, shall be cleaned and inspected at the end of each work day to ensure that the equipment is maintained in safe operating condition. Any equipment found to be defective will be brought to the attention of the SUXOS. Prior to leaving the EZ, and once the high lead contamination soil has been excavated, screened and transported, site equipment and vehicles, to include EMM, will be washed to remove visible soil and dirt. Washing of hand-held equipment and supplies will occur at the PDS, and the washing of large equipment, vehicles and EMM will occur at the soil stockpile area, where EODT will establish a poly-lined wash facility designed to capture run-off water from the washing process. Personnel involved in this form of washing shall wear Modified Level C PPE when washing equipment/vehicles after use in areas of high lead contamination. Personnel involved in the spray washing after equipment use only in the areas of low lead contamination shall wear Level D PPE.

Water collected as a result of equipment washing will be segregated according to the level of contamination (high lead or low lead) in the areas where the equipment was used. Washing solutions shall be stored in approved, labeled DOT containers and handled according to guidance from the CEHNC OSS.



13.0 ENGINEERING CONTROLS, SWP'S AND STANDING ORDERS

(No site-specific changes required for this Section. Refer to Section 13.0 of the the SEDA generic SSHP for data related to this Section.)

(This space intentionally left blank)



14.0 EMERGENCY RESPONSE / CONTINGENCY PROCEDURES

(No site-specific changes required for this Section. Refer to Section 14.0 of the SEDA generic SSHP for data related to this Section.)

(This space intentionally left blank)



15.0 LOGS, REPORTS, AUDITS, INSPECTIONS, AND RECORD KEEPING

(No site-specific changes required for this Section. Refer to Section 15.0 of the SEDA generic SSHP for data related to this Section.)

(This space intentionally left blank)

ATTACHMENT 1
OF THE
GENERIC SITE SAFETY AND HEALTH PLAN

CORPORATE SAFETY AND HEALTH
PROGRAM CERTIFICATION

FOR THE
ORDNANCE AND EXPLOSIVES OPERATIONS

SENECA ARMY DEPOT ACTIVITY, ROMULUS, NEW YORK

Contract Number: DACA87-97-D-0005
Task Order: 0003

Prepared For:

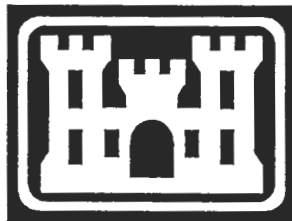

The U.S. Army Engineering and Support Center
Huntsville, Alabama

Prepared By:



2229 Old Highway 95
Lenior City, Tennessee 37771

June 1999

1.0: CSHP CERTIFICATION STATEMENT

(No site-specific changes required for this Attachment to the site-specific SSHP addendum for the Open Burning Grounds. See the Generic SSHP for the CSHP certification.)

(This space intentionally left blank.)

ATTACHMENT 2

OF THE

GENERIC SITE SAFETY AND HEALTH PLAN

GENERIC CERTIFICATION OF

TASK HAZARD ASSESSMENT FORMS

FOR THE

ORDNANCE AND EXPLOSIVES OPERATIONS

SENECA ARMY DEPOT ACTIVITY, ROMULUS, NEW YORK

Contract Number: DACA87-97-D-0005
Task Order: 0003

Prepared For:

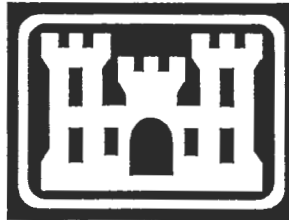

The U.S. Army Engineering and Support Center
Huntsville, Alabama

Prepared By:



2229 Old Highway 95
Lenior City, Tennessee 37771

June 1999



PREFACE

As a part of the SEDA Generic WP submission, EODT has previously submitted generic CTHA forms for those on-site activities which EODT has anticipated having to perform on a regular basis during OE operations within the SEDA facility. However, due to the heavy metal contamination at the OBG, and the need for enhanced PPE and decontamination requirements, no generic CTHA forms will apply to the OBG site operations. The site-specific CTHA forms listed below and presented in this Attachment will apply to the specified operations. Modifications to these CTHA forms may be made IAW the provisions of the SSHP.



TABLE OF CONTENTS

TASK	PAGE
Field Office, Storage Area and Work Zone Set-up and Close-out	A-2-1
Conduct Visual Sweep of the Site	A-2-2
Location Surveying and Mapping	A-2-3
Geophysical and Magnetometer Surveying	A-2-4
Anomaly Investigation	A-2-5
Demolition Operations	A-2-6
Earth Moving Machinery (EMM) Operation Within the Exclusion Zone	A-2-7
Screening Excavated Soils	A-2-8
Sorting Oversize Materials	A-2-9
Heavy Equipment, Vehicle and EMM Decontamination	A-2-10
Maintenance/Service of Machinery/Equipment	A-2-11



CERTIFICATION OF TASK HAZARD ASSESSMENT

TASK NAME: Field Office, Storage Area and Support Zone Set-up and Close Out

DATE: 5/27/99

1.0 Hazard Identification: Items checked are known or anticipated site hazards, or may occur as a result of site operations.

<input checked="" type="checkbox"/> Physical exertion	<input checked="" type="checkbox"/> Lifting hazards	<input type="checkbox"/> Confined space
<input checked="" type="checkbox"/> Heat Stress (during close-out)	<input checked="" type="checkbox"/> Slip, trip or fall	<input checked="" type="checkbox"/> Hazardous plants
<input checked="" type="checkbox"/> Cold Stress	<input checked="" type="checkbox"/> High noise (>85 dBA)	<input checked="" type="checkbox"/> Hazardous wildlife
<input checked="" type="checkbox"/> Heavy equipment operations	<input type="checkbox"/> Overhead utilities	<input checked="" type="checkbox"/> Ultraviolet radiation
<input checked="" type="checkbox"/> Vehicle traffic in work area(s)	<input type="checkbox"/> Underground utilities	<input checked="" type="checkbox"/> Hand/Power Tool use
<input checked="" type="checkbox"/> Fire hazards (underline)	<input type="checkbox"/> Intrusive activity (underline)	<input type="checkbox"/> Airborne chemical exposure
- Gasoline/Diesel use	- Soil drilling	<input checked="" type="checkbox"/> Skin contact w/ hazardous materials
- Explosives handling/storage	- Soil excavation	<input type="checkbox"/> Ordnance and explosives
- Explosive gases/vapors	- Setting grounding rod	<input checked="" type="checkbox"/> Cut/Puncture from sharp objects

2.0 Degree of Hazard: Anticipated degree of hazard, based on the hazards associated with this task.

Chemical Hazard:	<input checked="" type="checkbox"/> Low	<input type="checkbox"/> Serious	Phys./Bio. Hazard:	<input checked="" type="checkbox"/> Low	<input type="checkbox"/> Serious
	<input type="checkbox"/> Moderate	<input type="checkbox"/> Unknown		<input type="checkbox"/> Moderate	<input type="checkbox"/> Unknown

3.0 Control or Protective Measures: Items checked will be used to control or mitigate the above mentioned hazards.

<input checked="" type="checkbox"/> Tailgate Safety Briefing	<input checked="" type="checkbox"/> Personal protective equipment	<input checked="" type="checkbox"/> Decon - boot wash when exiting EZ
<input checked="" type="checkbox"/> Specialized Training	<input type="checkbox"/> Air Monitoring	<input type="checkbox"/> Magnetometer Survey
<input checked="" type="checkbox"/> Safe Work Practices	<input checked="" type="checkbox"/> Site Control Zones	

Engineering Controls: Tools with manufacturer supplied guards will be used with guards in place

Applicable SOPs/Programs: Cold and Heat Stress, Hearing Conservation, the SSHP

Other:

4.0 Task PPE: PPE has been assigned based on the potential for exposure as identified by this hazard assessment.

Level of Protection	<input type="checkbox"/> A <input type="checkbox"/> B	<input type="checkbox"/> C <input checked="" type="checkbox"/> D	<input type="checkbox"/> Modified
Respiratory Protection	<input type="checkbox"/> SCBA <input type="checkbox"/> Escape SCBA - Size	<input type="checkbox"/> Full face respirator <input type="checkbox"/> 1/2 Face respirator	<input type="checkbox"/> Cartridge - Type <input checked="" type="checkbox"/> No respirator required
Protective Clothing	<input type="checkbox"/> Fully encapsulating suit <input type="checkbox"/> Standard Tyvek	<input type="checkbox"/> Saranex <input type="checkbox"/> PE Tyvek	<input checked="" type="checkbox"/> Company clothing <input type="checkbox"/> Other:
Gloves (specify inner/outer)	<input type="checkbox"/> Nitrile <input type="checkbox"/> Butyl	<input type="checkbox"/> Neoprene <input type="checkbox"/> Latex	<input checked="" type="checkbox"/> Leather <input type="checkbox"/> Cotton
Head/Face/Eye/Ear Protection	<input checked="" type="checkbox"/> Safety glasses <input checked="" type="checkbox"/> Ear plugs/muffs	<input type="checkbox"/> Safety goggles <input type="checkbox"/> Face shield	<input checked="" type="checkbox"/> Hard hat <input type="checkbox"/> Other:
Foot/Leg Protection	<input checked="" type="checkbox"/> Leather boots ‡ <input type="checkbox"/> Steel-toed leather boots	<input type="checkbox"/> Steel foot covers <input type="checkbox"/> Kevlar leg chaps	<input checked="" type="checkbox"/> Chemical over boots

5.0 Modifications Required: † - Safety glasses required if eye hazards exist, to include UV hazard; ! - Ear plugs, muffs, or a combination of the two, will be used if noise levels exceed 85 dBA, 8-hour TWA; * - Hard hats around overhead hazards or when working around heavy equipment; ‡ - Leather boots are adequate unless a toe crush hazard exist; ⚡ - Required in EZ only.

6.0 Certification: The PPE and other control methods and procedures to be used in the conduct of this task have been selected as a result of a hazard assessment conducted by individual identified below.

Printed Name: Drew Bryson, CIH, MPH **Signature:**



CERTIFICATION OF TASK HAZARD ASSESSMENT

TASK NAME: Location Surveying and Mapping

DATE: 5/27/99

1.0 Hazard Identification: Items checked are known or anticipated site hazards, or may occur as a result of site operations.			
<input checked="" type="checkbox"/> Physical exertion <input checked="" type="checkbox"/> Heat Stress <input type="checkbox"/> Cold Stress <input type="checkbox"/> Heavy equipment operations <input type="checkbox"/> Vehicle traffic in work area(s) <input checked="" type="checkbox"/> Fire hazards (underline) - Gasoline/Diesel use - Explosive materials - Explosive gases/vapors	<input checked="" type="checkbox"/> Lifting hazards <input checked="" type="checkbox"/> Slip, trip or fall <input type="checkbox"/> High noise (>85 dBA) <input type="checkbox"/> Overhead utilities <input type="checkbox"/> Underground utilities <input checked="" type="checkbox"/> Intrusive activity (underline) - Drilling - Soil excavation - <u>Setting monuments/stakes</u>	<input type="checkbox"/> Confined space <input checked="" type="checkbox"/> Hazardous plants <input checked="" type="checkbox"/> Hazardous wildlife <input checked="" type="checkbox"/> Ultraviolet radiation <input checked="" type="checkbox"/> Hand/Power Tool use <input type="checkbox"/> Airborne chemical exposure <input type="checkbox"/> Skin contact w/ hazardous materials <input checked="" type="checkbox"/> Ordnance and explosives <input checked="" type="checkbox"/> Cut/Puncture from sharp objects	
2.0 Degree of Hazard: Anticipated degree of hazard, based on the hazards associated with this task.			
Chemical Hazard: <input checked="" type="checkbox"/> Low <input type="checkbox"/> Serious <input type="checkbox"/> Moderate <input type="checkbox"/> Unknown		Phys./Bio. Hazard: <input type="checkbox"/> Low <input type="checkbox"/> Serious <input checked="" type="checkbox"/> Moderate <input type="checkbox"/> Unknown	
3.0 Control or Protective Measures: Items checked will be used to control or mitigate the above mentioned hazards.			
<input checked="" type="checkbox"/> Tailgate Safety Briefing <input checked="" type="checkbox"/> Specialized Training <input checked="" type="checkbox"/> Safe Work Practices	<input checked="" type="checkbox"/> Personal protective equipment <input type="checkbox"/> Air Monitoring <input checked="" type="checkbox"/> Site Control Zones	<input checked="" type="checkbox"/> Decontamination - Boot wash. <input checked="" type="checkbox"/> Magnetometer monitoring prior to setting surveyor stakes	
<input type="checkbox"/> Engineering Controls:			
<input checked="" type="checkbox"/> Applicable SOPs/Programs: Heat Stress, the SSHP			
<input checked="" type="checkbox"/> Other: Overboot decontamination required if exiting areas of high lead levels.			
4.0 Task PPE: PPE has been assigned based on the potential for exposure as identified by this hazard assessment.			
Level of Protection	<input type="checkbox"/> A <input type="checkbox"/> B	<input type="checkbox"/> C <input checked="" type="checkbox"/> D	<input type="checkbox"/> Modified
Respiratory Protection	<input type="checkbox"/> SCBA <input type="checkbox"/> Escape SCBA - Size	<input type="checkbox"/> Full face respirator <input type="checkbox"/> ½ Face respirator	<input type="checkbox"/> Cartridge - Type <input checked="" type="checkbox"/> No respirator required
Protective Clothing	<input type="checkbox"/> Fully encapsulating suit <input type="checkbox"/> Standard Tyvek	<input type="checkbox"/> Saranex <input type="checkbox"/> PE Tyvek	<input checked="" type="checkbox"/> Company clothing <input type="checkbox"/> Other:
Gloves (specify inner/outer)	<input type="checkbox"/> Nitrile <input type="checkbox"/> Butyl	<input type="checkbox"/> Neoprene <input type="checkbox"/> Latex	<input checked="" type="checkbox"/> Leather <input type="checkbox"/> Cotton
Head/Face/Eye/Ear Protection	<input checked="" type="checkbox"/> Safety glasses * <input type="checkbox"/> Ear plugs/muffs	<input type="checkbox"/> Safety goggles <input type="checkbox"/> Face shield	<input type="checkbox"/> Hard hat <input type="checkbox"/> Other:
Foot/Leg Protection	<input checked="" type="checkbox"/> Leather boots <input type="checkbox"/> Steel-toed leather boots	<input type="checkbox"/> Steel foot covers <input checked="" type="checkbox"/> Snake leggings	<input checked="" type="checkbox"/> Chemical Over boots
5.0 Modifications Required: * - Tinted safety glasses required for UV protection in bright sunlight. † - Required for surveying in areas of high lead contamination. ‡ - If chemical heavy rubber and canvas over boots are not being worn, snake leggings will be worn in areas where encounters with snakes could occur, as determined by the SSO.			
6.0 Certification: The PPE and other control methods and procedures to be used in the conduct of this task have been selected as a result of a hazard assessment conducted by individual identified below.			
Printed Name: Drew Bryson, CIH, MPH		Signature:	



CERTIFICATION OF TASK HAZARD ASSESSMENT

TASK NAME: Conduct Visual Sweep of the Site

DATE: 5/27/99

1.0 Hazard Identification: Items checked are known or anticipated site hazards, or may occur as a result of site operations.			
<input checked="" type="checkbox"/> Physical exertion <input checked="" type="checkbox"/> Heat Stress <input type="checkbox"/> Cold Stress <input type="checkbox"/> Heavy equipment operations <input type="checkbox"/> Vehicle traffic in work area(s) <input type="checkbox"/> Fire hazards (underline) - Gasoline/Diesel use - Explosive materials - Explosive gases/vapors	<input type="checkbox"/> Lifting hazards <input checked="" type="checkbox"/> Slip, trip or fall <input type="checkbox"/> High noise (>85 dBA) <input type="checkbox"/> Overhead utilities <input type="checkbox"/> Underground utilities <input type="checkbox"/> Intrusive activity (underline) - Drilling - Soil excavation - Setting monuments/stakes	<input type="checkbox"/> Confined space <input checked="" type="checkbox"/> Hazardous plants <input checked="" type="checkbox"/> Hazardous wildlife <input checked="" type="checkbox"/> Ultraviolet radiation <input checked="" type="checkbox"/> Hand/Power Tool use <input type="checkbox"/> Airborne chemical exposure <input type="checkbox"/> Skin contact w/ hazardous materials <input checked="" type="checkbox"/> Ordnance and explosives <input checked="" type="checkbox"/> Cut/Puncture from sharp objects	
2.0 Degree of Hazard: Anticipated degree of hazard, based on the hazards associated with this task.			
Chemical Hazard: <input checked="" type="checkbox"/> Low <input type="checkbox"/> Serious <input type="checkbox"/> Moderate <input type="checkbox"/> Unknown		Phys./Bio. Hazard: <input type="checkbox"/> Low <input type="checkbox"/> Serious <input checked="" type="checkbox"/> Moderate <input type="checkbox"/> Unknown	
3.0 Control or Protective Measures: Items checked will be used to control or mitigate the above mentioned hazards.			
<input checked="" type="checkbox"/> Tailgate Safety Briefing <input checked="" type="checkbox"/> Specialized Training <input checked="" type="checkbox"/> Safe Work Practices <input type="checkbox"/> Engineering Controls:	<input checked="" type="checkbox"/> Personal protective equipment <input type="checkbox"/> Air Monitoring <input checked="" type="checkbox"/> Site Control Zones	<input checked="" type="checkbox"/> Decontamination - Boot wash. <input type="checkbox"/> Magnetometer	
<input checked="" type="checkbox"/> Applicable SOPs/Programs: Heat Stress, Biological Hazards, the SSHP <input type="checkbox"/> Other:			
4.0 Task PPE: PPE has been assigned based on the potential for exposure as identified by this hazard assessment.			
Level of Protection	<input type="checkbox"/> A <input type="checkbox"/> B	<input type="checkbox"/> C <input checked="" type="checkbox"/> D	<input type="checkbox"/> Modified
Respiratory Protection	<input type="checkbox"/> SCBA <input type="checkbox"/> Escape SCBA - Size	<input type="checkbox"/> Full face respirator <input type="checkbox"/> ½ Face respirator	<input type="checkbox"/> Cartridge - Type <input checked="" type="checkbox"/> No respirator required
Protective Clothing	<input type="checkbox"/> Fully encapsulating suit <input type="checkbox"/> Standard Tyvek	<input type="checkbox"/> Saranex <input type="checkbox"/> PE Tyvek	<input checked="" type="checkbox"/> Company clothing <input type="checkbox"/> Other:
Gloves (specify inner/outer)	<input type="checkbox"/> Nitrile <input type="checkbox"/> Butyl	<input type="checkbox"/> Neoprene <input type="checkbox"/> Latex	<input checked="" type="checkbox"/> Leather <input type="checkbox"/> Cotton
Head/Face/Eye/Ear Protection	<input checked="" type="checkbox"/> Safety glasses * <input type="checkbox"/> Ear plugs/muffs	<input type="checkbox"/> Safety goggles <input type="checkbox"/> Face shield	<input type="checkbox"/> Hard hat <input type="checkbox"/> Other:
Foot/Leg Protection	<input checked="" type="checkbox"/> Leather boots <input type="checkbox"/> Steel-toed leather boots	<input type="checkbox"/> Steel foot covers <input checked="" type="checkbox"/> Snake leggings	<input checked="" type="checkbox"/> Chemical Over boots
5.0 Modifications Required: * - Tinted safety glasses required for UV protection in bright sunlight. † - Required for surveying in areas of high lead contamination. # - If chemical heavy rubber and canvas overboots are not being worn, snake leggings will be worn in areas where encounters with snakes could occur, as determined by the SSO.			
6.0 Certification: The PPE and other control methods and procedures to be used in the conduct of this task have been selected as a result of a hazard assessment conducted by individual identified below.			
Printed Name: Drew Bryson, CIH, MPH		Signature:	



CERTIFICATION OF TASK HAZARD ASSESSMENT

TASK NAME: Magnetometer and Geophysical Surveying

DATE: 5/27/99

1.0 Hazard Identification: Items checked are known or anticipated site hazards, or may occur as a result of site operations.

<input checked="" type="checkbox"/> Physical exertion	<input type="checkbox"/> Lifting hazards	<input type="checkbox"/> Confined space
<input checked="" type="checkbox"/> Heat Stress	<input checked="" type="checkbox"/> Slip, trip or fall	<input checked="" type="checkbox"/> Hazardous plants
<input type="checkbox"/> Cold Stress	<input type="checkbox"/> High noise (>85 dBA)	<input checked="" type="checkbox"/> Hazardous wildlife
<input type="checkbox"/> Heavy equipment operations	<input type="checkbox"/> Overhead utilities	<input checked="" type="checkbox"/> Ultraviolet radiation
<input type="checkbox"/> Vehicle traffic in work area(s)	<input type="checkbox"/> Underground utilities	<input type="checkbox"/> Hand/Power Tool use
<input type="checkbox"/> Fire hazards (underline)	<input type="checkbox"/> Intrusive activity (underline)	<input type="checkbox"/> Airborne chemical exposure
- Gasoline/Diesel use	- Drilling	<input type="checkbox"/> Skin contact w/ hazardous materials
- Explosive materials	- Near Surface Soil excavation	<input checked="" type="checkbox"/> Ordnance and explosives
- Explosive gases/vapors	- Setting monuments/stakes	<input type="checkbox"/> Cut/Puncture from sharp objects

2.0 Degree of Hazard: Anticipated degree of hazard, based on the hazards associated with this task.

Chemical Hazard: <input checked="" type="checkbox"/> Low <input type="checkbox"/> Serious	<input type="checkbox"/> Moderate <input type="checkbox"/> Unknown	Phys./Bio. Hazard: <input type="checkbox"/> Low <input type="checkbox"/> Serious	<input checked="" type="checkbox"/> Moderate <input type="checkbox"/> Unknown
--	--	---	---

3.0 Control or Protective Measures: Items checked will be used to control or mitigate the above mentioned hazards.

<input checked="" type="checkbox"/> Tailgate Safety Briefing	<input checked="" type="checkbox"/> Personal protective equipment	<input checked="" type="checkbox"/> Decontamination - Boot wash
<input checked="" type="checkbox"/> Specialized Training	<input type="checkbox"/> Air Monitoring	<input checked="" type="checkbox"/> Magnetometer Survey
<input checked="" type="checkbox"/> Safe Work Practices	<input checked="" type="checkbox"/> Site Control Zones	

Engineering Controls:

Applicable SOPs/Programs: Heat Stress, Biological Hazards, the SSHP

Other:

4.0 Task PPE: PPE has been assigned based on the potential for exposure as identified by this hazard assessment.

Level of Protection	<input type="checkbox"/> A <input type="checkbox"/> B	<input type="checkbox"/> C <input checked="" type="checkbox"/> D	<input checked="" type="checkbox"/> Modified
Respiratory Protection	<input type="checkbox"/> SCBA <input type="checkbox"/> Escape SCBA - Size	<input type="checkbox"/> Full face respirator <input type="checkbox"/> 1/2 Face respirator	<input type="checkbox"/> Cartridge - Type <input checked="" type="checkbox"/> No respirator required
Protective Clothing	<input type="checkbox"/> Fully encapsulating suit <input type="checkbox"/> Standard Tyvek	<input type="checkbox"/> Saranex <input type="checkbox"/> PE Tyvek	<input checked="" type="checkbox"/> Company clothing <input type="checkbox"/> Other:
Gloves (specify inner/outer)	<input type="checkbox"/> Nitrile - During refueling <input type="checkbox"/> Butyl	<input type="checkbox"/> Neoprene <input type="checkbox"/> Latex	<input checked="" type="checkbox"/> Leather <input type="checkbox"/> Cotton
Head/Face/Eye/Ear Protection	<input checked="" type="checkbox"/> Safety glasses <input type="checkbox"/> Ear plugs or ear muffs	<input type="checkbox"/> Safety goggles <input type="checkbox"/> Wire or Nylon Face shield	<input type="checkbox"/> Hard hat <input type="checkbox"/> Other:
Foot/Leg Protection	<input checked="" type="checkbox"/> Leather boots <input type="checkbox"/> Steel-toed leather boots	<input type="checkbox"/> Steel Toe covers <input checked="" type="checkbox"/> Snake Leggings	<input checked="" type="checkbox"/> Chemical Over boots

5.0 Modifications Required: † - Chemical over boots will be worn during any magnetometer or geophysical surveying that is conducted in lead contaminated areas, however once lead contaminated soils are removed over boots will not be required. # - If chemical heavy rubber and canvas over boots are not being worn, snake leggings will be worn in areas where encounters with snakes could occur, as determined by the SSHP.

6.0 Certification: The PPE and other control methods and procedures to be used in the conduct of this task have been selected as a result of a hazard assessment conducted by individual identified below.

Printed Name: Drew Bryson, CIH, MPH **Signature:**



CERTIFICATION OF TASK HAZARD ASSESSMENT

TASK NAME: Anomaly Investigation

DATE: 5/27/99

1.0 Hazard Identification: Items checked are known or anticipated site hazards, or may occur as a result of site operations.			
<input checked="" type="checkbox"/> Physical exertion <input checked="" type="checkbox"/> Heat Stress <input type="checkbox"/> Cold Stress <input type="checkbox"/> Heavy equipment operations <input type="checkbox"/> Vehicle traffic in work area(s) <input type="checkbox"/> Fire hazards (underline) - Gasoline/Diesel use - Explosive materials - Explosive gases/vapors	<input checked="" type="checkbox"/> Lifting hazards <input checked="" type="checkbox"/> Slip, trip or fall <input type="checkbox"/> High noise (>85 dBA) <input type="checkbox"/> Overhead utilities <input type="checkbox"/> Underground utilities <input checked="" type="checkbox"/> Intrusive activity (underline) - Digging with EMM - <u>Hand digging soil</u> - Setting monuments/stakes	<input type="checkbox"/> Confined space <input checked="" type="checkbox"/> Hazardous plants <input checked="" type="checkbox"/> Hazardous wildlife <input checked="" type="checkbox"/> Ultraviolet radiation <input checked="" type="checkbox"/> Hand/Power Tool use <input type="checkbox"/> Airborne chemical exposure <input checked="" type="checkbox"/> Skin contact w/ hazardous materials <input checked="" type="checkbox"/> Ordnance and explosives <input checked="" type="checkbox"/> Cut/Puncture from sharp objects	
2.0 Degree of Hazard: Anticipated degree of hazard, based on the hazards associated with this task.			
Chemical Hazard: <input checked="" type="checkbox"/> Low <input type="checkbox"/> Serious <input type="checkbox"/> Moderate <input type="checkbox"/> Unknown		Phys./Bio. Hazard: <input type="checkbox"/> Low <input type="checkbox"/> Serious <input checked="" type="checkbox"/> Moderate <input type="checkbox"/> Unknown	
3.0 Control or Protective Measures: Items checked will be used to control or mitigate the above mentioned hazards.			
<input checked="" type="checkbox"/> Tailgate Safety Briefing <input checked="" type="checkbox"/> Specialized Training <input checked="" type="checkbox"/> Safe Work Practices	<input checked="" type="checkbox"/> Personal protective equipment <input type="checkbox"/> Air Monitoring <input checked="" type="checkbox"/> Site Control Zones	<input checked="" type="checkbox"/> Decontamination <input checked="" type="checkbox"/> Magnetometer Survey	
<input type="checkbox"/> Engineering Controls:			
<input checked="" type="checkbox"/> Applicable SOPs/Programs: Heat Stress, Biological Hazards, Hearing Conservation, the SSHP			
<input type="checkbox"/> Other:			
4.0 Task PPE: PPE has been assigned based on the potential for exposure as identified by this hazard assessment.			
Level of Protection	<input type="checkbox"/> A <input type="checkbox"/> B	<input checked="" type="checkbox"/> C <input type="checkbox"/> D	<input checked="" type="checkbox"/> Modified ‡
Respiratory Protection	<input type="checkbox"/> SCBA <input type="checkbox"/> Escape SCBA - Size	<input type="checkbox"/> Full face respirator <input type="checkbox"/> ½ Face respirator	<input type="checkbox"/> Cartridge - Type <input checked="" type="checkbox"/> No respirator required
Protective Clothing	<input type="checkbox"/> Fully encapsulating suit <input checked="" type="checkbox"/> Standard Tyvek ‡	<input type="checkbox"/> Saranex <input type="checkbox"/> PE Tyvek	<input checked="" type="checkbox"/> Company clothing <input type="checkbox"/> Other:
Gloves (specify inner/outer)	<input type="checkbox"/> Nitrile <input checked="" type="checkbox"/> Natural Rubber (outer) ‡	<input type="checkbox"/> Neoprene <input checked="" type="checkbox"/> Latex (inner) ‡	<input type="checkbox"/> Leather <input type="checkbox"/> Cotton
Head/Face/Eye/Ear Protection	<input type="checkbox"/> Safety glasses <input type="checkbox"/> Ear plugs/muffs	<input type="checkbox"/> Safety goggles <input type="checkbox"/> Face shield	<input type="checkbox"/> Hard hat <input type="checkbox"/> Other:
Foot/Leg Protection	<input checked="" type="checkbox"/> Leather boots <input type="checkbox"/> Steel-toed leather boots	<input type="checkbox"/> Steel foot covers <input checked="" type="checkbox"/> (#) Snake Leggings	<input checked="" type="checkbox"/> Chemical over boots †
5.0 Modifications Required: ‡ - Anomaly investigation in low lead contamination areas and areas where lead contamination has been removed will be accomplished in level D PPE as defined in the SSHP. † - Chemical over boots will be worn if investigating anomalies in low lead areas. # - If chemical heavy rubber and canvas overboots are not being worn, snake leggings will be worn in areas where encounters with snakes could occur, as determined by the SSHO.			
6.0 Certification: The PPE and other control methods and procedures to be used in the conduct of this task have been selected as a result of a hazard assessment conducted by individual identified below.			
Printed Name: Drew Bryson, CIH, MPH			Signature:



CERTIFICATION OF TASK HAZARD ASSESSMENT

TASK NAME: Demolition Operations

DATE: 5/27/99

1.0 Hazard Identification: Items checked are known or anticipated site hazards, or may occur as a result of site operations.			
<input checked="" type="checkbox"/> Physical exertion <input checked="" type="checkbox"/> Heat Stress <input type="checkbox"/> Cold Stress <input checked="" type="checkbox"/> Heavy equipment operations <input type="checkbox"/> Vehicle traffic in work area(s) <input checked="" type="checkbox"/> Fire hazards (underline) - Gasoline/Diesel use - <u>Demolition materials</u> - Explosive gases/vapors	<input checked="" type="checkbox"/> Lifting hazards <input checked="" type="checkbox"/> Slip, trip or fall <input checked="" type="checkbox"/> High noise (>85 dBA) <input type="checkbox"/> Overhead utilities <input type="checkbox"/> Underground utilities <input checked="" type="checkbox"/> Intrusive activity (underline) - Drilling - <u>Soil Tamping</u> - Setting monuments/stakes	<input type="checkbox"/> Confined space <input checked="" type="checkbox"/> Hazardous plants <input checked="" type="checkbox"/> Hazardous wildlife <input checked="" type="checkbox"/> Ultraviolet radiation <input checked="" type="checkbox"/> Hand/Power Tool use <input type="checkbox"/> Airborne chemical exposure <input type="checkbox"/> Skin contact w/ hazardous materials <input checked="" type="checkbox"/> Ordnance and explosives <input checked="" type="checkbox"/> Cut/Puncture from sharp objects	
2.0 Degree of Hazard: Anticipated degree of hazard, based on the hazards associated with this task.			
Chemical Hazard: <input checked="" type="checkbox"/> Low <input type="checkbox"/> Serious <input type="checkbox"/> Moderate <input type="checkbox"/> Unknown		Phys./Bio. Hazard: <input type="checkbox"/> Low <input checked="" type="checkbox"/> Serious <input type="checkbox"/> Moderate <input type="checkbox"/> Unknown	
3.0 Control or Protective Measures: Items checked will be used to control or mitigate the above mentioned hazards.			
<input checked="" type="checkbox"/> Tailgate Safety Briefing <input checked="" type="checkbox"/> Specialized Training <input checked="" type="checkbox"/> Safe Work Practices	<input checked="" type="checkbox"/> Personal protective equipment <input type="checkbox"/> Air Monitoring <input checked="" type="checkbox"/> Site Control Zones	<input checked="" type="checkbox"/> Decontamination - boot wash <input checked="" type="checkbox"/> Magnetometer Survey - post demo check of area	
<input checked="" type="checkbox"/> Engineering Controls: Soil tamping and other controls shall be used to ensure personnel exposure to impulse noise from the demolition shot(s) is less than 140 dBA.			
<input checked="" type="checkbox"/> Applicable SOPs/Programs: Heat Stress, Hearing Conservation, Demolition Operations, Biological Hazards the SSHP			
<input checked="" type="checkbox"/> Other: Personnel will stay clear of EMM when soil tamping is put in place.			
4.0 Task PPE: PPE has been assigned based on the potential for exposure as identified by this hazard assessment.			
Level of Protection	<input type="checkbox"/> A <input type="checkbox"/> B	<input type="checkbox"/> C <input checked="" type="checkbox"/> D	<input type="checkbox"/> Modified
Respiratory Protection	<input type="checkbox"/> SCBA <input type="checkbox"/> Escape SCBA - Size	<input type="checkbox"/> Full face respirator <input type="checkbox"/> ½ Face respirator	<input type="checkbox"/> Cartridge - Type <input checked="" type="checkbox"/> No respirator required
Protective Clothing	<input type="checkbox"/> Fully encapsulating suit <input type="checkbox"/> Standard Tyvek	<input type="checkbox"/> Saranex <input type="checkbox"/> PE Tyvek	<input checked="" type="checkbox"/> Company clothing <input type="checkbox"/> Other:
Gloves (specify inner/outer)	<input type="checkbox"/> Nitrile <input type="checkbox"/> Butyl	<input type="checkbox"/> Neoprene <input type="checkbox"/> Latex	<input checked="" type="checkbox"/> Leather <input type="checkbox"/> Cotton
Head/Face/Eye/Ear Protection	<input checked="" type="checkbox"/> Safety glasses <input type="checkbox"/> Ear plugs/muffs	<input type="checkbox"/> Safety goggles <input type="checkbox"/> Face shield	<input checked="" type="checkbox"/> Hard hat <input type="checkbox"/> Other:
Foot/Leg Protection	<input checked="" type="checkbox"/> Leather boots <input type="checkbox"/> Steel-toed leather boots	<input type="checkbox"/> Steel foot covers <input checked="" type="checkbox"/> Snake Leggings	<input checked="" type="checkbox"/> Chemical over boots - Material
5.0 Modifications Required: * - Hard hats required if overhead hazards exist or when working around EMM. Safety glasses and hard hat, if worn will be secured to prevent them from falling off the face/head. ‡ - If chemical heavy rubber and canvas over boots are not being worn, snake leggings will be worn in areas where encounters with snakes could occur, as determined by the SSHO.			
6.0 Certification: The PPE and other control methods and procedures to be used in the conduct of this task have been selected as a result of a hazard assessment conducted by individual identified below.			
Printed Name: Drew Bryson, CIH, MPH		Signature:	



CERTIFICATION OF TASK HAZARD ASSESSMENT

TASK NAME: Earth Moving Machinery (EMM) Operation (during any task or any location)

DATE: 5/27/99

1.0 Hazard Identification: Items checked are known or anticipated site hazards, or may occur as a result of site operations.			
<input checked="" type="checkbox"/> Physical exertion <input checked="" type="checkbox"/> Heat Stress <input type="checkbox"/> Cold Stress <input checked="" type="checkbox"/> Heavy equipment operations <input type="checkbox"/> Vehicle traffic in work area(s) <input checked="" type="checkbox"/> Fire hazards (underline) - Gasoline/Diesel use - Explosive materials - Explosive gases/vapors	<input type="checkbox"/> Lifting hazards <input checked="" type="checkbox"/> Slip, trip or fall <input checked="" type="checkbox"/> High noise (>85 dBA) <input type="checkbox"/> Overhead utilities <input type="checkbox"/> Underground utilities <input checked="" type="checkbox"/> Intrusive activity (underline) - Drilling - Soil excavation - Setting monuments/stakes	<input type="checkbox"/> Confined space <input type="checkbox"/> Hazardous plants <input type="checkbox"/> Hazardous wildlife <input checked="" type="checkbox"/> Ultraviolet radiation <input checked="" type="checkbox"/> Hand/Power Tool use <input checked="" type="checkbox"/> Airborne chemical exposure <input type="checkbox"/> Skin contact w/ hazardous materials <input checked="" type="checkbox"/> Ordnance and explosives <input type="checkbox"/> Cut/Puncture from sharp objects	
2.0 Degree of Hazard: Anticipated degree of hazard, based on the hazards associated with this task.			
Chemical Hazard: <input checked="" type="checkbox"/> Low <input type="checkbox"/> Serious <input type="checkbox"/> Moderate <input type="checkbox"/> Unknown		Phys./Bio. Hazard: <input checked="" type="checkbox"/> Low <input type="checkbox"/> Serious <input type="checkbox"/> Moderate <input type="checkbox"/> Unknown	
3.0 Control or Protective Measures: Items checked will be used to control or mitigate the above mentioned hazards.			
<input checked="" type="checkbox"/> Tailgate Safety Briefing <input checked="" type="checkbox"/> Specialized Training <input checked="" type="checkbox"/> Safe Work Practices	<input checked="" type="checkbox"/> Personal protective equipment <input checked="" type="checkbox"/> Air Monitoring <input checked="" type="checkbox"/> Site Control Zones	<input checked="" type="checkbox"/> Decontamination <input checked="" type="checkbox"/> Magnetometer Survey <input checked="" type="checkbox"/> Visual UXO/OE Survey	
<input type="checkbox"/> Engineering Controls:			
<input checked="" type="checkbox"/> Applicable SOPs/Programs: Heat Stress, EMM Operation, Hearing Conservation, the SSHP			
<input checked="" type="checkbox"/> Other: Safety observer will be stationed to watch operator and excavation. Personnel will be trained in the proper use of the EMM, to include general maintenance and safety.			
4.0 Task PPE: PPE has been assigned based on the potential for exposure as identified by this hazard assessment.			
Level of Protection	<input type="checkbox"/> A <input type="checkbox"/> B	<input checked="" type="checkbox"/> C ‡ <input type="checkbox"/> D	<input type="checkbox"/> Modified
Respiratory Protection	<input type="checkbox"/> SCBA <input type="checkbox"/> Escape SCBA - Size	<input checked="" type="checkbox"/> Full face respirator ‡ <input type="checkbox"/> ½ Face respirator	<input checked="" type="checkbox"/> Cartridge - HEPA ‡ <input type="checkbox"/> No respirator required
Protective Clothing	<input type="checkbox"/> Fully encapsulating suit <input checked="" type="checkbox"/> Standard Tyvek ‡	<input type="checkbox"/> Saranex <input type="checkbox"/> PE Tyvek	<input checked="" type="checkbox"/> Company clothing <input type="checkbox"/> Other:
Gloves (specify inner/outer)	<input checked="" type="checkbox"/> Nitrile - During refueling <input checked="" type="checkbox"/> Natural rubber (outer) ‡	<input type="checkbox"/> Neoprene <input checked="" type="checkbox"/> Latex (inner) ‡	<input type="checkbox"/> Leather <input type="checkbox"/> Cotton
Head/Face/Eye/Ear Protection	<input type="checkbox"/> Safety glasses <input type="checkbox"/> Ear plugs or ear muffs	<input type="checkbox"/> Safety goggles <input type="checkbox"/> Wire or Nylon Face shield	<input checked="" type="checkbox"/> Hard hat <input type="checkbox"/> Other:
Foot/Leg Protection	<input type="checkbox"/> Leather boots <input checked="" type="checkbox"/> Steel-toed leather boots	<input type="checkbox"/> Steel Toe covers <input type="checkbox"/> Kevlar leg chaps	<input checked="" type="checkbox"/> Chemical Over boots ‡
5.0 Modifications Required: ‡ - Operators within enclosed cabs, to include dump trucks, may wear Level D PPE; soil excavation from low lead areas will be conducted in Level D PPE.. ! - Ear plugs will be worn initially and thereafter as directed by the SSO.			
6.0 Certification: The PPE and other control methods and procedures to be used in the conduct of this task have been selected as a result of a hazard assessment conducted by individual identified below.			
Printed Name: Drew Bryson, CIH, MPH		Signature:	



CERTIFICATION OF TASK HAZARD ASSESSMENT

TASK NAME: Sifting of Excavated Soils

DATE: 5/27/99

1.0 Hazard Identification: Items checked are known or anticipated site hazards, or may occur as a result of site operations.

<input checked="" type="checkbox"/> Physical exertion	<input type="checkbox"/> Lifting hazards	<input type="checkbox"/> Confined space
<input checked="" type="checkbox"/> Heat Stress	<input checked="" type="checkbox"/> Slip, trip or fall	<input type="checkbox"/> Hazardous plants
<input type="checkbox"/> Cold Stress	<input checked="" type="checkbox"/> High noise (>85 dBA)	<input type="checkbox"/> Hazardous wildlife
<input checked="" type="checkbox"/> Heavy equipment operations	<input type="checkbox"/> Overhead utilities	<input checked="" type="checkbox"/> Ultraviolet radiation
<input type="checkbox"/> Vehicle traffic in work area(s)	<input type="checkbox"/> Underground utilities	<input checked="" type="checkbox"/> Hand/Power Tool use
<input checked="" type="checkbox"/> Fire hazards (underline)	<input type="checkbox"/> Intrusive activity (underline)	<input checked="" type="checkbox"/> Airborne chemical exposure
- Gasoline/Diesel use	- Drilling	<input type="checkbox"/> Skin contact w/ hazardous materials
- Explosive materials	- Soil excavation	<input checked="" type="checkbox"/> Ordnance and explosives
- Explosive gases/vapors	- Setting monuments/stakes	<input type="checkbox"/> Cut/Puncture from sharp objects

2.0 Degree of Hazard: Anticipated degree of hazard, based on the hazards associated with this task.

Chemical Hazard:	<input type="checkbox"/> Low	<input type="checkbox"/> Serious	Phys./Bio. Hazard:	<input type="checkbox"/> Low	<input type="checkbox"/> Serious
	<input checked="" type="checkbox"/> Moderate	<input type="checkbox"/> Unknown		<input checked="" type="checkbox"/> Moderate	<input type="checkbox"/> Unknown

3.0 Control or Protective Measures: Items checked will be used to control or mitigate the above mentioned hazards.

<input checked="" type="checkbox"/> Tailgate Safety Briefing	<input checked="" type="checkbox"/> Personal protective equipment	<input checked="" type="checkbox"/> Decontamination
<input checked="" type="checkbox"/> Specialized Training	<input checked="" type="checkbox"/> Air Monitoring	<input type="checkbox"/> Magnetometer Survey
<input checked="" type="checkbox"/> Safe Work Practices	<input checked="" type="checkbox"/> Site Control Zones	<input checked="" type="checkbox"/> Visual checks for OE

Engineering Controls:

Applicable SOPs/Programs: Heat Stress, Mechanical Screening, Hearing Conservation, the SSHP

Other: UXO qualified safety observer will be stationed to watch operation.

4.0 Task PPE: PPE has been assigned based on the potential for exposure as identified by this hazard assessment.

Level of Protection	<input type="checkbox"/> A <input type="checkbox"/> B	<input checked="" type="checkbox"/> C ‡ <input type="checkbox"/> D	<input type="checkbox"/> Modified
Respiratory Protection	<input type="checkbox"/> SCBA <input type="checkbox"/> Escape SCBA - Size	<input checked="" type="checkbox"/> Full face respirator ‡ <input type="checkbox"/> ½ Face respirator	<input checked="" type="checkbox"/> Cartridge - HEPA ‡ <input type="checkbox"/> No respirator required
Protective Clothing	<input type="checkbox"/> Fully encapsulating suit <input checked="" type="checkbox"/> Standard Tyvek ‡	<input type="checkbox"/> Saranex <input type="checkbox"/> PE Tyvek	<input checked="" type="checkbox"/> Company clothing <input type="checkbox"/> Other:
Gloves (specify inner/outer)	<input checked="" type="checkbox"/> Nitrile - During refueling <input checked="" type="checkbox"/> Natural rubber (outer) ‡	<input type="checkbox"/> Neoprene <input checked="" type="checkbox"/> Latex (inner) ‡	<input type="checkbox"/> Leather <input type="checkbox"/> Cotton
Head/Face/Eye/Ear Protection	<input type="checkbox"/> Safety glasses <input checked="" type="checkbox"/> Ear plugs or ear muffs	<input type="checkbox"/> Safety goggles <input type="checkbox"/> Wire or Nylon Face shield	<input checked="" type="checkbox"/> Hard hat <input type="checkbox"/> Other:
Foot/Leg Protection	<input type="checkbox"/> Leather boots <input checked="" type="checkbox"/> Steel-toed leather boots	<input type="checkbox"/> Steel Toe covers <input type="checkbox"/> Kevlar leg chaps	<input checked="" type="checkbox"/> Chemical Over boots ‡

5.0 Modifications Required: ‡ - Operators within enclosed cabs, to include dump trucks, may wear Level D PPE; soil excavation from low lead areas will be conducted in Level D PPE.. ! - Ear plugs will be worn initially and thereafter as directed by the SSHO.

6.0 Certification: The PPE and other control methods and procedures to be used in the conduct of this task have been selected as a result of a hazard assessment conducted by individual identified below.

Printed Name: Drew Bryson, CIH, MPH

Signature:



CERTIFICATION OF TASK HAZARD ASSESSMENT

TASK NAME: Sorting of Oversize Materials

DATE: 5/27/99

1.0 Hazard Identification: Items checked are known or anticipated site hazards, or may occur as a result of site operations.

<input checked="" type="checkbox"/> Physical exertion	<input checked="" type="checkbox"/> Lifting hazards	<input type="checkbox"/> Confined space
<input checked="" type="checkbox"/> Heat Stress	<input checked="" type="checkbox"/> Slip, trip or fall	<input type="checkbox"/> Hazardous plants
<input type="checkbox"/> Cold Stress	<input checked="" type="checkbox"/> High noise (>85 dBA)	<input type="checkbox"/> Hazardous wildlife
<input checked="" type="checkbox"/> Heavy equipment operations	<input type="checkbox"/> Overhead utilities	<input checked="" type="checkbox"/> Ultraviolet radiation
<input type="checkbox"/> Vehicle traffic in work area(s)	<input type="checkbox"/> Underground utilities	<input checked="" type="checkbox"/> Hand/Power Tool use
<input checked="" type="checkbox"/> Fire hazards (underline)	<input type="checkbox"/> Intrusive activity (underline)	<input type="checkbox"/> Airborne chemical exposure
- Gasoline/Diesel use	- Drilling	<input checked="" type="checkbox"/> Skin contact w/ hazardous materials
- Explosive materials	- Soil excavation	<input checked="" type="checkbox"/> Ordnance and explosives
- Explosive gases/vapors	- Setting monuments/stakes	<input checked="" type="checkbox"/> Cut/Puncture from sharp objects

2.0 Degree of Hazard: Anticipated degree of hazard, based on the hazards associated with this task.

Chemical Hazard:	<input checked="" type="checkbox"/> Low	<input type="checkbox"/> Serious	Phys./Bio. Hazard:	<input type="checkbox"/> Low	<input type="checkbox"/> Serious
	<input type="checkbox"/> Moderate	<input type="checkbox"/> Unknown		<input checked="" type="checkbox"/> Moderate	<input type="checkbox"/> Unknown

3.0 Control or Protective Measures: Items checked will be used to control or mitigate the above mentioned hazards.

<input checked="" type="checkbox"/> Tailgate Safety Briefing	<input checked="" type="checkbox"/> Personal protective equipment	<input checked="" type="checkbox"/> Decontamination
<input checked="" type="checkbox"/> Specialized Training	<input type="checkbox"/> Air Monitoring	<input type="checkbox"/> Magnetometer Survey
<input checked="" type="checkbox"/> Safe Work Practices	<input checked="" type="checkbox"/> Site Control Zones	<input checked="" type="checkbox"/> Visual UXO/OE Survey

Engineering Controls:

Applicable SOPs/Programs: Heat Stress, EMM Operation, Hearing Conservation, the SSHP

Other: If hopper becomes clogged, entire line will shut down prior to personnel attempting to clear hopper.

4.0 Task PPE: PPE has been assigned based on the potential for exposure as identified by this hazard assessment.

Level of Protection	<input type="checkbox"/> A <input type="checkbox"/> B	<input checked="" type="checkbox"/> C <input type="checkbox"/> D	<input checked="" type="checkbox"/> Modified ‡
Respiratory Protection	<input type="checkbox"/> SCBA <input type="checkbox"/> Escape SCBA - Size	<input type="checkbox"/> Full face respirator <input checked="" type="checkbox"/> ½ Face respirator	<input type="checkbox"/> Cartridge - Type <input checked="" type="checkbox"/> No respirator required
Protective Clothing	<input type="checkbox"/> Fully encapsulating suit <input checked="" type="checkbox"/> Standard Tyvek ‡	<input type="checkbox"/> Saranex <input type="checkbox"/> PE Tyvek	<input checked="" type="checkbox"/> Company clothing <input type="checkbox"/> Other:
Gloves (specify inner/outer)	<input type="checkbox"/> Nitrile <input checked="" type="checkbox"/> Natural Rubber (outer) ‡	<input type="checkbox"/> Neoprene <input checked="" type="checkbox"/> Latex (inner) ‡	<input type="checkbox"/> Leather <input type="checkbox"/> Cotton
Head/Face/Eye/Ear Protection	<input type="checkbox"/> Safety glasses <input type="checkbox"/> Ear plugs/muffs	<input type="checkbox"/> Safety goggles <input type="checkbox"/> Face shield	<input type="checkbox"/> Hard hat <input type="checkbox"/> Other:
Foot/Leg Protection	<input checked="" type="checkbox"/> Leather boots <input type="checkbox"/> Steel-toed leather boots	<input type="checkbox"/> Steel foot covers <input checked="" type="checkbox"/> Snake Leggings	<input checked="" type="checkbox"/> Chemical over boots †

5.0 Modifications Required: ‡ - Sorting of over size material from low lead areas will be accomplished in level D PPE as defined in the SSHP. † - If chemical heavy rubber and canvas over boots are not being worn, snake leggings will be worn in areas where encounters with snakes could occur, as determined by the SSHA. ! - Sorting oversize from high lead level areas may require the use of a ½-face respirator, as determined by sampling results and the SSHA.

6.0 Certification: The PPE and other control methods and procedures to be used in the conduct of this task have been selected as a result of a hazard assessment conducted by individual identified below.

Printed Name: Drew Bryson, CIH, MPH **Signature:** 



CERTIFICATION OF TASK HAZARD ASSESSMENT

TASK NAME: Non-Hand Held Equipment, Vehicle and EMM Decontamination

DATE: 5/27/99

1.0 Hazard Identification: Items checked are known or anticipated site hazards, or may occur as a result of site operations.

<input checked="" type="checkbox"/> Physical exertion	<input type="checkbox"/> Lifting hazards	<input type="checkbox"/> Confined space
<input checked="" type="checkbox"/> Heat Stress	<input checked="" type="checkbox"/> Slip, trip or fall	<input type="checkbox"/> Hazardous plants
<input type="checkbox"/> Cold Stress	<input checked="" type="checkbox"/> High noise (>85 dBA)	<input type="checkbox"/> Hazardous wildlife
<input checked="" type="checkbox"/> Heavy equipment operations	<input type="checkbox"/> Overhead utilities	<input checked="" type="checkbox"/> Ultraviolet radiation
<input type="checkbox"/> Vehicle traffic in work area(s)	<input type="checkbox"/> Underground utilities	<input checked="" type="checkbox"/> Hand/Power Tool use
<input checked="" type="checkbox"/> Fire hazards (underline)	<input type="checkbox"/> Intrusive activity (underline)	<input type="checkbox"/> Airborne chemical exposure
- Gasoline/Diesel use	- Drilling	<input checked="" type="checkbox"/> Skin contact w/ hazardous materials
- Explosive materials	- Soil excavation	<input type="checkbox"/> Ordnance and explosives
- Explosive gases/vapors	- Setting monuments/stakes	<input type="checkbox"/> Cut/Puncture from sharp objects

2.0 Degree of Hazard: Anticipated degree of hazard, based on the hazards associated with this task.

Chemical Hazard: <input checked="" type="checkbox"/> Low	<input type="checkbox"/> Serious	Phys./Bio. Hazard: <input checked="" type="checkbox"/> Low	<input type="checkbox"/> Serious
<input type="checkbox"/> Moderate	<input type="checkbox"/> Unknown	<input type="checkbox"/> Moderate	<input type="checkbox"/> Unknown

3.0 Control or Protective Measures: Items checked will be used to control or mitigate the above mentioned hazards.

<input checked="" type="checkbox"/> Tailgate Safety Briefing	<input checked="" type="checkbox"/> Personal protective equipment	<input checked="" type="checkbox"/> Decontamination
<input checked="" type="checkbox"/> Specialized Training	<input type="checkbox"/> Air Monitoring	<input type="checkbox"/> Magnetometer Survey
<input checked="" type="checkbox"/> Safe Work Practices	<input checked="" type="checkbox"/> Site Control Zones	

Engineering Controls:

Applicable SOPs/Programs: Heat Stress, EMM Operation, Hearing Conservation, the SSHP

Other:

4.0 Task PPE: PPE has been assigned based on the potential for exposure as identified by this hazard assessment.

Level of Protection	<input type="checkbox"/> A <input type="checkbox"/> B	<input checked="" type="checkbox"/> C <input type="checkbox"/> D	<input checked="" type="checkbox"/> Modified
Respiratory Protection	<input type="checkbox"/> SCBA <input type="checkbox"/> Escape SCBA - Size	<input type="checkbox"/> Full face respirator <input type="checkbox"/> 1/2 Face respirator	<input type="checkbox"/> Cartridge - Type <input checked="" type="checkbox"/> No respirator required
Protective Clothing	<input type="checkbox"/> Fully encapsulating suit <input checked="" type="checkbox"/> Standard Tyvek	<input type="checkbox"/> Saranex <input type="checkbox"/> PE Tyvek	<input checked="" type="checkbox"/> Company clothing <input type="checkbox"/> Other:
Gloves (specify inner/outer)	<input checked="" type="checkbox"/> Nitrile - During refueling <input checked="" type="checkbox"/> Natural rubber (outer)	<input type="checkbox"/> Neoprene <input checked="" type="checkbox"/> Latex (inner)	<input type="checkbox"/> Leather <input type="checkbox"/> Cotton
Head/Face/Eye/Ear Protection	<input checked="" type="checkbox"/> Safety glasses <input checked="" type="checkbox"/> Ear plugs or ear muffs	<input type="checkbox"/> Safety goggles <input checked="" type="checkbox"/> Plastic Face shield	<input checked="" type="checkbox"/> Hard hat <input type="checkbox"/> Other:
Foot/Leg Protection	<input checked="" type="checkbox"/> Leather work boots <input type="checkbox"/> Steel-toed leather boots	<input type="checkbox"/> Steel Toe covers <input type="checkbox"/> Kevlar leg chaps	<input checked="" type="checkbox"/> Chemical Over boots

5.0 Modifications Required: ‡ - Equipment decontamination for equipment that has only been in low lead contamination areas may be conducted in Level D PPE without the use of tyvek.

6.0 Certification: The PPE and other control methods and procedures to be used in the conduct of this task have been selected as a result of a hazard assessment conducted by individual identified below.

Printed Name: Drew Bryson, CIH, MPH

Signature:



CERTIFICATION OF TASK HAZARD ASSESSMENT

TASK NAME: Maintenance/Service of Machinery/Equipment

DATE: 5/27/99

1.0 Hazard Identification: Items checked are known or anticipated site hazards, or may occur as a result of site operations.			
<input checked="" type="checkbox"/> Physical exertion <input checked="" type="checkbox"/> Heat Stress <input type="checkbox"/> Cold Stress <input checked="" type="checkbox"/> Heavy equipment operations <input type="checkbox"/> Vehicle traffic in work area(s) <input checked="" type="checkbox"/> Fire hazards (underline) - Gasoline/Diesel use - Explosive materials - <u>use of solvents</u>	<input checked="" type="checkbox"/> Lifting hazards <input checked="" type="checkbox"/> Slip, trip or fall <input checked="" type="checkbox"/> High noise (>85 dBA) <input type="checkbox"/> Overhead utilities <input type="checkbox"/> Underground utilities <input type="checkbox"/> Intrusive activity (underline) - Drilling - Soil excavation - Setting monuments/stakes	<input type="checkbox"/> Confined space <input type="checkbox"/> Hazardous plants <input type="checkbox"/> Hazardous wildlife <input checked="" type="checkbox"/> Ultraviolet radiation <input checked="" type="checkbox"/> Hand/Power Tool use <input type="checkbox"/> Airborne chemical exposure <input checked="" type="checkbox"/> Skin contact w/ hazardous materials <input checked="" type="checkbox"/> Hazardous energy sources <input checked="" type="checkbox"/> Cut/Puncture from sharp objects	
2.0 Degree of Hazard: Anticipated degree of hazard, based on the hazards associated with this task.			
Chemical Hazard: <input checked="" type="checkbox"/> Low <input type="checkbox"/> Serious <input type="checkbox"/> Moderate <input type="checkbox"/> Unknown		Phys./Bio. Hazard: <input type="checkbox"/> Low <input type="checkbox"/> Serious <input checked="" type="checkbox"/> Moderate <input type="checkbox"/> Unknown	
3.0 Control or Protective Measures: Items checked will be used to control or mitigate the above mentioned hazards.			
<input checked="" type="checkbox"/> Tailgate Safety Briefing <input checked="" type="checkbox"/> Specialized Training <input checked="" type="checkbox"/> Safe Work Practices	<input checked="" type="checkbox"/> Personal protective equipment <input type="checkbox"/> Air Monitoring <input type="checkbox"/> Site Control Zones	<input type="checkbox"/> Decontamination <input type="checkbox"/> Magnetometer Survey	
<input checked="" type="checkbox"/> Engineering Controls: All equipment/machinery maintenance and service activities shall be assessed by the SSHO to determine if Lockout/Tagout procedures are to be implemented during the required maintenance/service.			
<input checked="" type="checkbox"/> Applicable SOPs/Programs: Heat and Cold Stress, Control of Hazardous Energy, the SSHP.			
<input checked="" type="checkbox"/> Other: If possible (i.e., machinery/equipment may be moved) decontaminate equipment prior to maintenance/service.			
4.0 Task PPE: PPE has been assigned based on the potential for exposure as identified by this hazard assessment.			
Level of Protection	<input type="checkbox"/> A <input type="checkbox"/> B	<input type="checkbox"/> C <input checked="" type="checkbox"/> D	<input type="checkbox"/> Modified
Respiratory Protection	<input type="checkbox"/> SCBA <input type="checkbox"/> Escape SCBA - Size	<input type="checkbox"/> Full face respirator <input type="checkbox"/> ½ Face respirator	<input type="checkbox"/> Cartridge - Type <input checked="" type="checkbox"/> No respirator required
Protective Clothing	<input type="checkbox"/> Fully encapsulating suit <input type="checkbox"/> Standard Tyvek	<input type="checkbox"/> Saranex <input type="checkbox"/> PE Tyvek	<input checked="" type="checkbox"/> Company clothing <input type="checkbox"/> Other:
Gloves (specify inner/outer)	<input type="checkbox"/> Nitrile <input type="checkbox"/> Butyl	<input type="checkbox"/> Neoprene <input type="checkbox"/> Latex	<input checked="" type="checkbox"/> Leather <input type="checkbox"/> Cotton
Head/Face/Eye/Ear Protection	<input checked="" type="checkbox"/> Safety glasses <input checked="" type="checkbox"/> Ear plugs/muffs	<input type="checkbox"/> Safety goggles <input type="checkbox"/> Face shield	<input checked="" type="checkbox"/> Hard hat <input type="checkbox"/> Other:
Foot/Leg Protection	<input checked="" type="checkbox"/> Leather boots <input type="checkbox"/> Steel-toed leather boots	<input type="checkbox"/> Steel foot covers <input checked="" type="checkbox"/> Snake Leggings	<input checked="" type="checkbox"/> Chemical over boots
5.0 Modifications Required: § - Leather gloves required if hand injury hazard exists. ! - Ear plugs, muffs, or a combination of the two, will be used if noise levels exceed 85 dBA, 8-hour TWA; * - Hard hats required if an overhead hazard exists or when working around heavy equipment; ‡ - Over boots required if working in the EZ.			
6.0 Certification: The PPE and other control methods and procedures to be used in the conduct of this task have been selected as a result of a hazard assessment conducted by individual identified below.			
Printed Name: Drew Bryson, CIH, MPH		Signature:	

APPENDIX B
TO
ADDENDUM 1 OF THE GENERIC WORK PLAN
FOR THE
ORDNANCE AND EXPLOSIVES REMOVAL
AT THE
OPEN BURNING GROUNDS
SENECA ARMY DEPOT ACTIVITY
ROMULUS, NEW YORK
SCOPE OF WORK

Contract Number: DACA87-97-D-0005
Task Order: 0003

Prepared For:

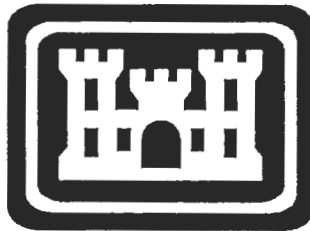

U.S. Army Engineering and Support Center
Huntsville, Alabama

Prepared By:



2229 Old Highway 95
Lenoir City, Tennessee 37771

June 1999



This appendix contains the SOW for contract number DACA87-97-D-0005, Task Order 0003, for the OE Removal Action at the Open Burning Grounds, Seneca Army Depot Activity, Romulus, New York.

(This space intentionally left blank.)

SCOPE OF WORK
SOIL EXCAVATION, SCREENING, AND REMOVAL ACTIONS
AT THE
OPEN BURNING GROUNDS (OBG)
SENECA ARMY DEPOT ACTIVITY (SEDA)
ROMULUS, NEW YORK
March 19, 1999

For the purposes of this SOW, "contractor" refers to EOD Technology, Inc. (EODT), while "subcontractor" refers to the offeror.

1 GENERAL

1.1 The OBG consists of approximately 30 acres (see Parsons' Figure 3, "Location of Soil to be Excavated," attached). The soil type is glacial till. However, the pads beneath the nine berms (identified as "A" through "J" on Parsons' Figure 3), as well as the roadways, are of crushed shale. The serpentine-like low-lying hill in the lower part of Parsons' Figure 3 is composed of glacial till.

1.2 The pads, berms, and low-lying hill are contaminated with OE and lead. The OE Removal Action will remove the OE, while a separate work effort will address stabilizing the lead in the soil.

1.3 All work performed in support of the OE Removal Actions will be performed under the Comprehensive Environmental Response Compensation and Liability Act (CERCLA), therefore, no environmental permitting is required.

1.4 SEDA is a controlled installation; therefore, compliance with their security requirements is mandatory. These include the subcontractor furnishing SEDA security officials with a list of their employees 72 hours prior to commencement of work. Other security requirements will be communicated upon award of the subcontract and have no bearing on costs.

2 SOIL EXCAVATION, SCREENING, AND REMOVAL ACTIONS

2.1 OE must be removed from the soil in the existing berms, pads, and the low-lying hill adjacent to the OBG so the lead-contaminated soil can be safely stabilized. The OE-free soil and debris must then be transported to a prepared site 0.75 miles from the OBG. Project specifics and assumptions related to this objective are as follows:

2.1.1 All soil and debris removed from the OBG must be free of OE larger than or equal in size to a 20 mm projectile;

2.1.2 The screening process must prevent all OE greater than or equal to a 20 mm from leaving the screens;

2.1.3 EODT is responsible for removing all OE and OE-related scrap greater than 20 mm that is rejected by the screening process;

2.1.4 The subcontractor is responsible for transporting all non-OE debris to the prepared site referenced above;

- 2.1.5 The soil to be screened will come from the berms, pads, the low-lying hill, and the top one foot of the 30-acre site, minus the roadways with low-lying hill comprising 7.5 acres of the total;
- 2.1.6 The quantity of soil to be screened is approximately 63,000 cy;
 - 2.1.6.1 Case I soils [containing >800 parts per million (ppm) of lead] comprise approximately 16,000 cy, located in multiple areas;
 - 2.1.6.2 Case II soils (containing between 500 and 800 ppm of lead) comprise approximately 2,000 cy, located in multiple areas;
 - 2.1.6.3 Case III soils (containing <500 ppm of lead) comprise the remainder of the volume, located in multiple areas;
- 2.1.7 Soil will be excavated and screened by cases, and all equipment will be decontaminated between cases;
 - 2.1.7.1 Decontamination will be done by another subcontractor;
- 2.1.8 The berms, pads, and the low-lying hill will be excavated and sifted by cases, from most contaminated to least contaminated;
- 2.1.9 The pads and berms contain approximately 11,000 cubic yards (cy) of clean and lead-contaminated soils (see Parsons' Figure 3 for a breakdown, by case type);
- 2.1.10 The low-lying hill contains approximately 6,000 cy of clean and lead-contaminated soil;
- 2.1.11 Due to the requirement to remove all lead-contaminated soil, regardless of depth, some locations within the berms and pads will require excavation down to a maximum of 8 ft;
- 2.1.12 The subcontractor will provide all run-on/-off and storm water/erosion controls;
- 2.1.13 Backfill will be provided by another subcontractor;
- 2.1.14 The subcontractor will transport screened soil and non-OE debris to a prepared stockpile site (another subcontractor is responsible for site preparation and stockpile management);
- 2.1.15 All surveying required to identify locations to be excavated (including identifying specific locations by case type), together with testing and stabilization of lead-contaminated soils will be done by others;
- 2.1.16 Since the OBG roadways are considered OE free, the subcontractor should use these roadways to the maximum extent possible; however, should off-road vehicle or equipment travel be required, these will be swept by EODT for OE;
- 2.1.17 An EODT unexploded ordnance (UXO) specialist must observe the screening operation;
 - 2.1.17.1 The subcontractor will provide a remote-controlled telescoping platform, scissor lift, or other suitable apparatus that allows the UXO specialist to observe the screening process, looking for OE entering the screening processor;
 - 2.1.17.2 The subcontractor will mount a 3-in sheet of plexiglass (provided by EODT) on the

SCOPE OF WORK
SOIL EXCAVATION, SCREENING, AND REMOVAL ACTIONS
AT THE
OPEN BURNING GROUNDS (OBG)
SENECA ARMY DEPOT ACTIVITY (SEDA)
ROMULUS, NEW YORK
March 19, 1999

For the purposes of this SOW, "contractor" refers to EOD Technology, Inc. (EODT), while "subcontractor" refers to the offeror.

1 GENERAL

1.1 The OBG consists of approximately 30 acres (see Parsons' Figure 3, "Location of Soil to be Excavated," attached). The soil type is glacial till. However, the pads beneath the nine berms (identified as "A" through "J" on Parsons' Figure 3), as well as the roadways, are of crushed shale. The serpentine-like low-lying hill in the lower part of Parsons' Figure 3 is composed of glacial till.

1.2 The pads, berms, and low-lying hill are contaminated with OE and lead. The OE Removal Action will remove the OE, while a separate work effort will address stabilizing the lead in the soil.

1.3 All work performed in support of the OE Removal Actions will be performed under the Comprehensive Environmental Response Compensation and Liability Act (CERCLA), therefore, no environmental permitting is required.

1.4 SEDA is a controlled installation; therefore, compliance with their security requirements is mandatory. These include the subcontractor furnishing SEDA security officials with a list of their employees 72 hours prior to commencement of work. Other security requirements will be communicated upon award of the subcontract and have no bearing on costs.

2 SOIL EXCAVATION, SCREENING, AND REMOVAL ACTIONS

2.1 OE must be removed from the soil in the existing berms, pads, and the low-lying hill adjacent to the OBG so the lead-contaminated soil can be safely stabilized. The OE-free soil and debris must then be transported to a prepared site 0.75 miles from the OBG. Project specifics and assumptions related to this objective are as follows:

2.1.1 All soil and debris removed from the OBG must be free of OE larger than or equal in size to a 20 mm projectile;

2.1.2 The screening process must prevent all OE greater than or equal to a 20 mm from leaving the screens;

2.1.3 EODT is responsible for removing all OE and OE-related scrap greater than 20 mm that is rejected by the screening process;

2.1.4 The subcontractor is responsible for transporting all non-OE debris to the prepared site referenced above;

- 2.1.5 The soil to be screened will come from the berms, pads, the low-lying hill, and the top one foot of the 30-acre site, minus the roadways with low-lying hill comprising 7.5 acres of the total;
- 2.1.6 The quantity of soil to be screened is approximately 63,000 cy;
- 2.1.6.1 Case I soils [containing >800 parts per million (ppm) of lead] comprise approximately 16,000 cy, located in multiple areas;
- 2.1.6.2 Case II soils (containing between 500 and 800 ppm of lead) comprise approximately 2,000 cy, located in multiple areas;
- 2.1.6.3 Case III soils (containing <500 ppm of lead) comprise the remainder of the volume, located in multiple areas;
- 2.1.7 Soil will be excavated and screened by cases, and all equipment will be decontaminated between cases;
- 2.1.7.1 Decontamination will be done by another subcontractor;
- 2.1.8 The berms, pads, and the low-lying hill will be excavated and sifted by cases, from most contaminated to least contaminated;
- 2.1.9 The pads and berms contain approximately 11,000 cubic yards (cy) of clean and lead-contaminated soils (see Parsons' Figure 3 for a breakdown, by case type);
- 2.1.10 The low-lying hill contains approximately 6,000 cy of clean and lead-contaminated soil;
- 2.1.11 Due to the requirement to remove all lead-contaminated soil, regardless of depth, some locations within the berms and pads will require excavation down to a maximum of 8 ft;
- 2.1.12 The subcontractor will provide all run-on/-off and storm water/erosion controls;
- 2.1.13 Backfill will be provided by another subcontractor;
- 2.1.14 The subcontractor will transport screened soil and non-OE debris to a prepared stockpile site (another subcontractor is responsible for site preparation and stockpile management);
- 2.1.15 All surveying required to identify locations to be excavated (including identifying specific locations by case type), together with testing and stabilization of lead-contaminated soils will be done by others;
- 2.1.16 Since the OBG roadways are considered OE free, the subcontractor should use these roadways to the maximum extent possible; however, should off-road vehicle or equipment travel be required, these will be swept by EODT for OE;
- 2.1.17 An EODT unexploded ordnance (UXO) specialist must observe the screening operation;
- 2.1.17.1 The subcontractor will provide a remote-controlled telescoping platform, scissor lift, or other suitable apparatus that allows the UXO specialist to observe the screening process, looking for OE entering the screening processor;
- 2.1.17.2 The subcontractor will mount a 3-in sheet of plexiglass (provided by EODT) on the

telescoping platform, scissor lift, or other suitable apparatus according to drawings provided by EODT (see Figure 120B-1 from EODT Standard Operating Procedure 120-B, “UXO/OEW Operations – Mechanical Sifting,” attached);

2.1.17.3 The subcontractor will provide the EODT UXO specialist with a “kill switch,” enabling him to stop the screening operation if he sees an OE item entering the processor (the UXO specialist and the CEHNC On-Site Safety Specialist (OSS) will then evaluate the OE to determine the next course of action);

2.1.17.4 Anticipated screening processor down time for OE evaluation and removal is 20 minutes per event, with events occurring twice daily;

2.1.17.5 The subcontractor will mount 3 inch plexiglass on all equipment potentially coming in contact with OE (EODT will provide the plexiglass) in order to protect personnel; as a minimum this includes the excavator and telescoping platform, scissor lift, or other suitable apparatus;

2.1.17.6 Only essential personnel are permitted to be within 400 ft of screening operations; all others 850 ft;

2.1.18 Workers should wear Level D; however, higher levels of personal protective equipment may be necessary, based on monitoring;

2.1.18.1 The subcontractor may chose to provide EODT with an appendix to their Health and Safety Plan or provide an independent one;

2.1.18.2 All workers must be certified in accordance with 29 CFR 1910.120;

2.1.18.3 The subcontractor must provide dust control;

2.1.18.4 Air monitoring will be provided by the contractor;

2.1.18.5 The subcontractor is not permitted into the OBG without EODT escort;

2.1.19 EODT plans to work 4, ten-hour days with the 5th day reserved as a possible make-up day;

2.1.20 The Seneca County, New York, service contract wage rates apply;

2.1.21 The subcontractor may use a portion of the office space currently assigned to EODT;

2.1.22 The EODT portable toilet is also available for subcontractor use;

2.1.23 CEHNC anticipates the project beginning in late April or early May.

2.2 Note: The subcontractor providing equipment decontamination (see paragraph 2.1.14) has proposed that they also provide site de-watering support; however, if the excavation and screening subcontractor could demonstrate efficiencies by conducting the de-watering activities, that portion of the work will be awarded to them. Please provide separate costing for de-watering activities.

3 OTHER ISSUES.

3.1 Productivity target is between 800 and 1,000 cy per day.

3.2 The volume of soil will be based on a survey done by another subcontractor; however, EODT will consider alternative methods of calculating the volume.

3.3 Payment will be made by the volume (in cy) of soil successfully screened and delivered to the stockpile area.

APPENDIX C
TO
ADDENDUM 1 OF THE GENERIC WORK PLAN
FOR THE
ORDNANCE AND EXPLOSIVES REMOVAL
AT THE
OPEN BURNING GROUNDS
SENECA ARMY DEPOT ACTIVITY
ROMULUS, NEW YORK
SITE MAPS

Contract Number: DACA87-97-D-0005

Task Order: 0003

Prepared For:



U.S. Army Engineering and Support Center
Huntsville, Alabama

Prepared By:



2229 Old Highway 95
Lenoir City, Tennessee 37771

June 1999



TABLE OF CONTENTS

Map Number	Project Map Name
1	Open Burning Ground Site Map

(This space intentionally left blank.)



P. O. Box 24173
 Knoxville, Tennessee 37932-2173
 (423) 988-6063 (423) 988-6067
 e-mail: eodt@eodt.com

Legend:

Project Work Site: 

OBG Boundary: 

Edge of Berm: 

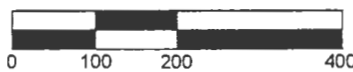
Scale
 In Feet: 



Seneca Army Depot Activity, Open Burning Grounds

Site Overview Map

Drawing Version No.: 1 Rev. 0

Drawn by: JKD

Contract Number: DACA87-97-D-0005

Figure Number

Date: 06/04/99

Checked by: ALB/MES

Task Order Number: 0007

C-1

APPENDIX D
TO
ADDENDUM 1 OF THE GENERIC WORK PLAN
FOR THE
ORDNANCE AND EXPLOSIVES REMOVAL
AT THE
OPEN BURNING GROUNDS
SENECA ARMY DEPOT ACTIVITY
ROMULUS, NEW YORK
POINTS OF CONTACT

Contract Number: DACA87-97-D-0005
Task Order: 0003

Prepared For:

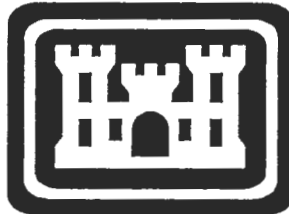

U.S. Army Engineering and Support Center
Huntsville, Alabama

Prepared By:



2229 Old Highway 95
Lenoir City, Tennessee 37771

June 1999



POINTS OF CONTACT

1. EMERGENCY SERVICES---911

Hospital (non-trauma):

Geneva General Hospital (315) 798-4222

Hospital (trauma):

Syracuse University Hospital (contact and transport to this facility by EMS only)

Police:

SEDA Police/Security (607) 869-0448

Local EOD:

725th Ordnance Company (EOD) (315) 772-5408

Fire:

SEDA Fire Department (607) 869-1316

Air Ambulance:

Mercy Flight 911

Surface Ambulance:

South Seneca Ambulance 911

2. KEY PERSONNEL

A. CEHNC Personnel

Fred Wissel, Project Manager (205) 895-1552

Karen Butler, Contracting Officer (205) 895-1151

_____, Safety Officer (205) 895-

Kevin Healy, Lead Engineer (205) 895-1627

B. SEDA and New York Corps Personnel

Steve Absalom, BRAC Environmental Coordinator (607) 869-1309

Randall Battaglio, NY Corps of Engineers Project Manager (607) 869-1523



C. EODT Personnel

Michael Short, Program Manager (423) 988-6063
Bill Pearse, Project Manager (423) 988-6063
Andrew Bryson, CIH, Program Safety/Training (423) 988-6063
Michael Short, QA/QC Manager (423) 988-6063

(This space intentionally left blank)

APPENDIX E
TO
ADDENDUM 1 OF THE GENERIC WORK PLAN
FOR THE
ORDNANCE AND EXPLOSIVES REMOVAL
AT THE
OPEN BURNING GROUNDS
SENECA ARMY DEPOT ACTIVITY
ROMULUS, NEW YORK
SAMPLE FORMS

Contract Number: DACA87-97-D-0005
Task Order: 0003

Prepared For:



U.S. Army Engineering and Support Center
Huntsville, Alabama

Prepared By:



2229 Old Highway 95
Lenior City, Tennessee 37771

June 1999



TABLE OF SAMPLE FORMS

The sample forms to be used for the implementation of the SOW for Addendum 1 for the OE removal at the OBG are enclosed in the Appendix E of the SEDA Generic WP. Site personnel will refer to Appendix E of the Generic WP for the appropriate documents.

(This space intentionally left blank.)

APPENDIX F
TO
ADDENDUM 1 OF THE GENERIC WORK PLAN
FOR THE
ORDNANCE AND EXPLOSIVES REMOVAL
AT THE
OPEN BURNING GROUNDS
SENECA ARMY DEPOT ACTIVITY
ROMULUS, NEW YORK
RESUMES

Contract Number: DACA87-97-D-0005
Task Order: 0003

Prepared For:

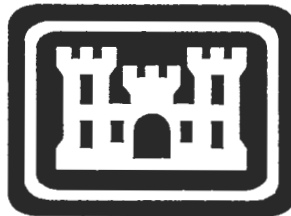

U.S. Army Engineering and Support Center
Huntsville, Alabama

Prepared By:



2229 Old Highway 95
Lenoir City, Tennessee 37771

June 1999



The resumes for the EODT key personnel (i.e., the Program Manager, PM, OSHM and SUXOS) are presented in the Appendix F of the Generic WP, with the exception of Mr. Bill Pearse. Current plans are for the remainder of the key personnel to remain the same for the execution of this TO. In the event that personnel changes occur prior to, or during site operations at the OBG, the updated resume(s) will be included in this Appendix.

(This space intentionally left blank.)

WILLIAM M. PEARSE
PROJECT MANAGER

CITIZENSHIP	USA
B. S. CHEMISTRY, RENSSELAER POLYTECHNIC INSTITUTE	1975
M. S. NUCLEAR ENGINEERING, CORNELL UNIVERSITY	1977
CERTIFIED HAZARDOUS MATERIALS MANAGER	1986
PROFESSIONAL EXPERIENCE	20 YEARS

- Provisionally Certified ISO 14000 Auditor, 1997
- Certified Hazardous Materials Manager, Master Level, 1986
- B.S., Chemistry, Rensselaer Polytechnic Institute, Troy, NY
- M.S., Nuclear Engineering, Cornell University, Ithaca, NY

Mr. Pearse has nearly 20 years experience in the project management, environmental consulting and technical services industry. Responsible for new business development in manufacturing, process, and utility industrial segments. Demonstrated ability to expand business in highly competitive circumstances by maintaining strong relationships with existing customers as well as through the development and implementation of customer-specific sales pursuits for new opportunities. Experience includes full range of management responsibilities: P/L, strategic planning, personnel administration, budgeting, contracts, and project execution. Exceptional written and verbal communication skills.

- Managed five HTRW projects with a combined value of \$11.6M.
- Increased sales by developing more than \$9 million in new commercial accounts in key geography.
- Developed and sold new process-oriented environmental consulting services which now accounts for more than \$10 million annually in revenues.
- Wrote and executed business plan to grow office revenues and staff ten-fold in four years in flat business climate. Made financial targets five consecutive years.
- Penetrated major pharmaceutical account against ten competing firms with major award.
- Developed project management control systems still in use after ten years.
- Piloted on-line comprehensive sales information system currently in use.
- Instrumental in reorganizing 200-person engineering branch from engineering discipline basis to project team basis.
- Wrote documents critical to implementation of \$50 million radioactive waste management program.
- Prepared and delivered more than 50 presentations to audience ranging up to 1,000 people.

WORK HISTORY

Polymath

Principal

1996-Present

ABB Environmental Services, Inc. (a business unit of Asea Brown Boveri)

Director, Business Development

1993-1996

Manager, Tennessee Operations

1989-1993

Tennessee Valley Authority

Assistant Branch Chief

1987-1989

Environmental Compliance Manager

1978-1987

APPENDIX G
TO
ADDENDUM 1 OF THE GENERIC WORK PLAN
FOR THE
ORDNANCE AND EXPLOSIVES REMOVAL
AT THE
OPEN BURNING GROUNDS
SENECA ARMY DEPOT ACTIVITY
ROMULUS, NEW YORK
STANDARD OPERATING PROCEDURES

Contract Number: DACA87-97-D-0005

Task Order: 0003

Prepared For:

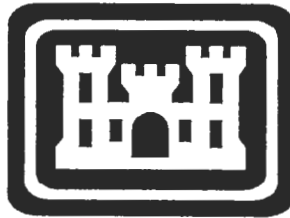

U.S. Army Engineering and Support Center
Huntsville, Alabama

Prepared By:



2229 Old Highway 95
Lenoir City, Tennessee 37771

June 1999



TABLE OF CONTENTS

The SOPs that will apply to the performance of the OE removal at the OBG are listed below. The actual SOP's to be referenced have been submitted previously as part of Appendix G in the SEDA Generic WP, with the exception of SOP 120B Mechanical Screening, which has been included in this WP Addendum. The tab numbers presented below correlate to the tab numbers in Appendix G of the Generic WP. In the event that any further site-specific SOPs must be submitted, they will also be amended to this Appendix.

WP Tab Number	Standard Operating Procedure
1	Safety Concepts and Basic Considerations
2	Biological Hazards
4	Fire Prevention and Protection
5	Hazard Communication
6	Heat Stress Prevention
8	Material Handling and Lifting
9	Hearing Conservation
10	Sanitation, Housekeeping and Illumination
11	Power and Hand Tool Operation
14	Disposal/Demolition Operations
13	Explosives Acquisition, Storage, Accountability, and Transport
15	Rules and Prohibited Practices

SOP's Amended to this Appendix

<i>IA</i>	<i>Mechanical Screening</i>
-----------------	-----------------------------

STANDARD OPERATING PROCEDURE 120-B

UXO/OEW OPERATIONS - MECHANICAL SCREENING

1.0 PURPOSE

The purpose of this Standard Operating Procedure (SOP) is to outline the minimum safety and health requirements and procedures applicable to the conduct of material separation operations involving the use of mechanical screening equipment.

2.0 SCOPE

This SOP applies to all site personnel, to include EODT, contractor, and subcontractor personnel, and operations involving the separation of material through the use of mechanical screening equipment. This SOP is not intended to contain all requirements needed to ensure regulatory compliance and is generic in nature. Site-specific requirements for blast shields, plexiglass and safety arcs are presented in the figures attached to this SOP when it is added to a Site Safety and Health Plan. Additionally, consult the documents listed in section 3.0 of this SOP for additional compliance issues.

3.0 REGULATORY REFERENCES

The following Occupational Safety and Health Administration (OSHA) standards and U.S. Army Corps of Engineers (USACE) requirements directly apply to the conduct of operations associated with the SOP. In the event other hazards are associated with the conduct of this SOP, consultation of other SOPs and regulatory references may be needed.

- OSHA Construction Industry Standard 29 CFR Part 1926, Subpart O;
- OSHA General Industry Standard 29 CFR Part 1910, Subparts N and O; and
- USACE EM 385-1-1, Sections 16 A and B and Section 17 A.

4.0 RESPONSIBILITIES

4.1 PROJECT MANAGER

The Project Manager shall be responsible for ensuring the availability of the EODT resources needed to implement this SOP, and shall ensure that this SOP is incorporated in the plans, procedures and training for sites where mechanical screening is to be implemented.

4.2 SENIOR UXO SUPERVISOR

The Senior UXO Supervisor (SUXOS) will ensure that this SOP is implemented for screening operations, and that relevant sections of this SOP are discussed in the tailgate safety briefings. Information related to the daily implementation of the SOP is to be documented in the Site Operational Log maintained by the SUXOS.

4.3 UXO SUPERVISOR

The UXO Supervisor (UXOS) shall be responsible for ensuring the field implementation of this SOP and for implementing the safety and health requirements outlined in section 5.0 of this SOP. In the absence of a SUXOS, the UXOS shall be responsible for implementing the SUXOS responsibilities outlined in para 4.2.

4.4 SITE SAFETY AND HEALTH OFFICER

The Site Safety and Health Officer (SSHO) will be responsible for ensuring that the safety and health hazards and control techniques associated with this SOP are discussed during the initial site hazard training and the daily tailgate safety briefings. The SSHO will also be responsible for daily inspection of site operations and conditions to ensure their initial and continued compliance with this SOP and other regulatory guidelines.

5.0 PROCEDURE

All EODT, contractor, and subcontractor personnel involved in screening operations shall be familiar with the potential safety and health hazards associated with this operation. Additionally, all effected personnel shall also be familiar with the control techniques that will used to reduce or eliminate these hazards.

5.1 SAFETY HAZARDS

The safety and health hazards potentially associated with mechanical screening operations on an ordnance and explosives (OE) site are listed below. For each of the hazards listed, at least one hazard control measure is listed in paragraph 5.2 for the reduction of the operational hazard. At no time will mechanical screening operations be conducted on site without the use and implementation of the appropriate controls measures.

1. Unexploded ordnance (UXO), possibly resulting in heat, fire, fragmentation, and over pressurization hazards;
2. Vehicle traffic and movement
3. Trips and falls (excavations and man lift)
4. Noise;
5. Heavy equipment operations;
6. Dust, with potential for exposure to toxic metals;
7. Stored energy and pinch points; and
8. Engine exhaust.

5.2 OPERATIONAL CONTROL MEASURES

For the safety hazards listed in paragraph 5.1, the operational control measures presented below shall be used to the greatest extent feasible, to protect site personnel from the hazards associated and

identified with mechanical screening operations. The degree and type of hazard, as outlined in the site Work Plan (WP) and Site Safety and Health Plan (SSHP) will determine the extent of control to be used, however, all of the safety measures listed below will be implemented.

1. Daily tailgate safety meetings will be conducted, and noted in the Safety Log, as to the safety and health concerns pertaining to overall operations and the use of screening equipment.
2. Screening equipment and support vehicles shall be equipped with fire extinguishers.
3. The excavation operations will not require barricading, however, both the excavator and the UXO Specialist (UXOSP) will be protected behind a plexiglass window of the thickness specified in Figure 120B-1. ***For the loader/excavator operator, the plexiglass will be mounted over the existing windshield and windows.*** For the UXOSP observing the excavation, the plexiglass window will be mounted on a blast shield similar to that portrayed in Figure 120B-1. At a minimum, the blast shield shall provide front, side and overhead and be constructed to the material thickness specifications depicted. General design characteristics and dimensions of the plexiglass and steel sides required have been specified by Dr. Crull, Structures Branch, Engineering Directorate, US Army Engineering and Support Center, Huntsville (CEHNC). The dimensions were selected based upon the accidental detonation of the most probable munitions (MPM) for the specific site.
4. The mechanical screening assembly will not require barricading; however, the UXO personnel controlling and monitoring the screening, along with the UXOSP monitoring the screen reject material, will be protected behind plexiglass windows mounted on separate blast shields. The blast shields used shall be constructed similar to the blast shield depicted in Figure 120B-1 of this SOP. The UXO personnel controlling the screen will do so by means of a remotely-wired "kill switch." This kill switch will be capable of shutting down the screening operations should the UXOSP monitoring the operation detect an OE item within the screen or screen reject. The location of the UXOSP monitoring the screening process will be such that the UXOSP will be able to see the screening area. This may require the use of a man lift to allow for visual observation of the operation. If needed, the blast shield will be mounted on the man lift platform.
5. ***All operational observers described above will be located outside the K24 distance arc of 19.4 feet for the MPM specified for the site.*** To fill the sifter hopper, the loader operator will be passing temporarily into and out of the K24 distance arc, and as such will be required to wear hearing protection at all times. This will be in addition to the plexiglass shielding that will be installed on all excavation and loading equipment.
6. The UXOSP controlling the screening operation will watch for any materials that may be UXO items and any items that may become lodged/jammed in the screens. If any potential UXO is seen in the hopper, on the conveyors, in the screens, or in the reject material, the screening process will be shut down immediately. Additionally, if a potential UXO is observed in the screen reject, the UXOSP observing the item will use

APPENDIX H
TO
ADDENDUM 1 OF THE GENERIC WORK PLAN
FOR THE
ORDNANCE AND EXPLOSIVES REMOVAL
AT THE
OPEN BURNING GROUNDS
SENECA ARMY DEPOT ACTIVITY
ROMULUS, NEW YORK
MATERIAL SAFETY DATA SHEETS

Contract Number: DACA87-97-D-0005

Task Order: 0003

Prepared For:

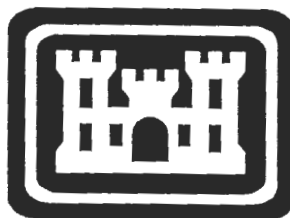

U.S. Army Engineering and Support Center
Huntsville, Alabama

Prepared By:



2229 Old Highway 95
Lenoir City, Tennessee 37771

June 1999



The general MSDSs anticipated for this project have been included in Appendix H to the Generic WP. If site-specific products that contain hazardous materials are used, the MSDS for the material will be amended to this Appendix.

(This space intentionally left blank.)

radio or visual communication to order the immediate shut-down of the screening operations. Once the process has been halted and secured, the potential UXO item will be inspected by the UXOSPs. If the item is confirmed as being a UXO, the item will be identified and a determination made as to whether the item can be moved. Those items that are unfuzed or safe to move will be removed from the screening equipment and stored for later disposal according to the approved Work Plan (WP). Those items determined to be unsafe to move will be left in place, the CEHNC on-site Safety Specialist will be notified, and the screening operations halted until such time as a resolution can be obtained using the procedures in the approved WP. Those items identified as being OE-related but not UXO will be removed and stored accordingly.

7. Segregation of the oversize materials will be performed according to the following:
 - a. Debris identified as rocks, roots, shale, etc., will be collected and combined with the screened soil from which they came.
 - b. The debris is identified as non-OE scrap that will be disposed of as scrap.
 - c. The debris is identified as OE-related scrap or inert OE and must be verified as being free of OE hazards prior to scrap disposal.
 - d. The debris is identified as UXO that is unfuzed and safe to move, in which case the item will be removed from the area and destroyed at the existing OD area.
 - d. Hazardous UXO identified that cannot be moved, will be brought to the attention of the SUXOS who will immediately notify the USAESCH OSS. The OSS will direct EODT as to the next course of action to be taken.
8. When maintenance/servicing is performed on the sifter or conveyor system, all sources of immediate power or stored energy shall be controlled (refer to lockout/tagout SOP).
9. Screening operations shall be restricted to daylight hours, and once operations begin, only UXO-qualified personnel may enter the safety zone around the sifter operation.
10. All personnel involved in the screening operations shall be informed of the "Kill Switch" location, as well as the procedures for summoning emergency support.

5.2 SAFETY AND PERSONAL PROTECTIVE EQUIPMENT REQUIREMENTS

The following safety measures and personal protective equipment (PPE) shall be used in preventing or reducing exposures associated with screening operations. These requirements will be implemented unless superseded by site specific requirements stated in the SSHP.

1. Hard hats, steel-toe safety boots and protective gloves shall be worn when ever maintenance, adjustment or clearing of the sifter is being performed.
2. Safety glasses shall be worn around screening equipment unless full face respirators are required; and
3. Any of the PPE that will be worn when investigating OE items in the sifter will be secured to the wearer to ensure that it does not fall off and strike suspect UXO items;

4. Hearing protection shall be worn when screening equipment is in operation unless the SSHO has measured and determined the noise levels to be less than 85 decibels on the “A” scale over an 8-hour time-weighted average.

6.0 AUDIT CRITERIA

The following items related to screening operations will be audited to ensure compliance with this SOP:

1. The Daily Operational and Safety Logs;
2. The Documentation of Training form for the initial site hazard training;
3. The Documentation of Training form for the Daily Tailgate Safety Briefings; and
4. The Daily Safety Inspection Checklist.

7.0 ATTACHMENTS

No attachments associated with this SOP.

Figure 120B-1. Blast Shielding for Remote Sifter Operator or Excavation Observer

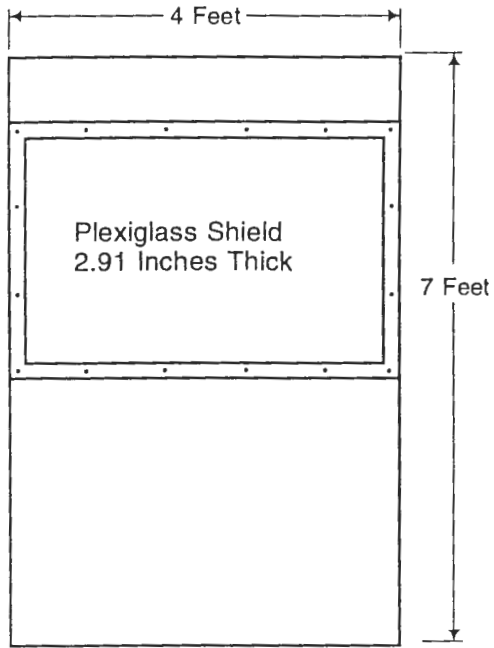

Front View

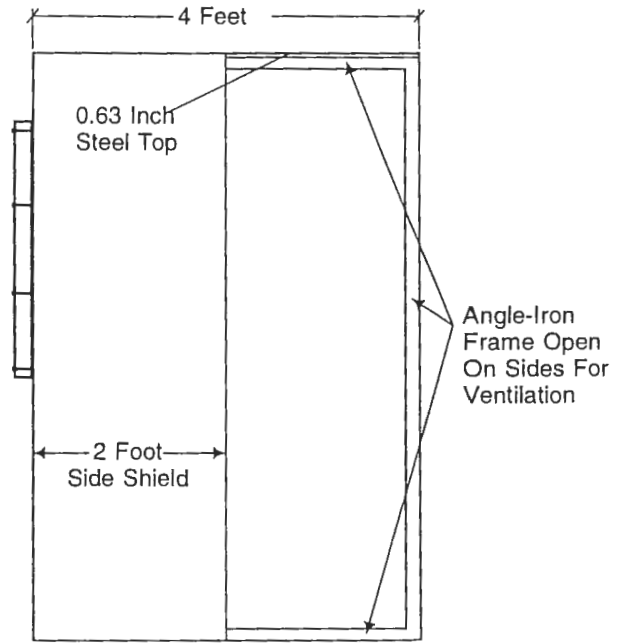

Right Side View

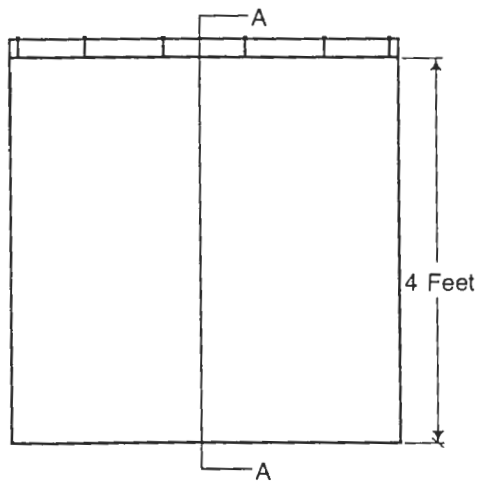

Top View

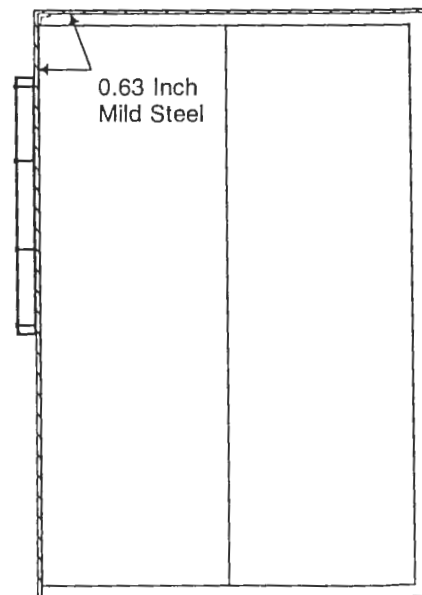

Cross Section A - A

are approximate, and different configurations may be used upon approval of CEHNC. Additionally, plexiglass may cover entire front of blast shield.